

84582

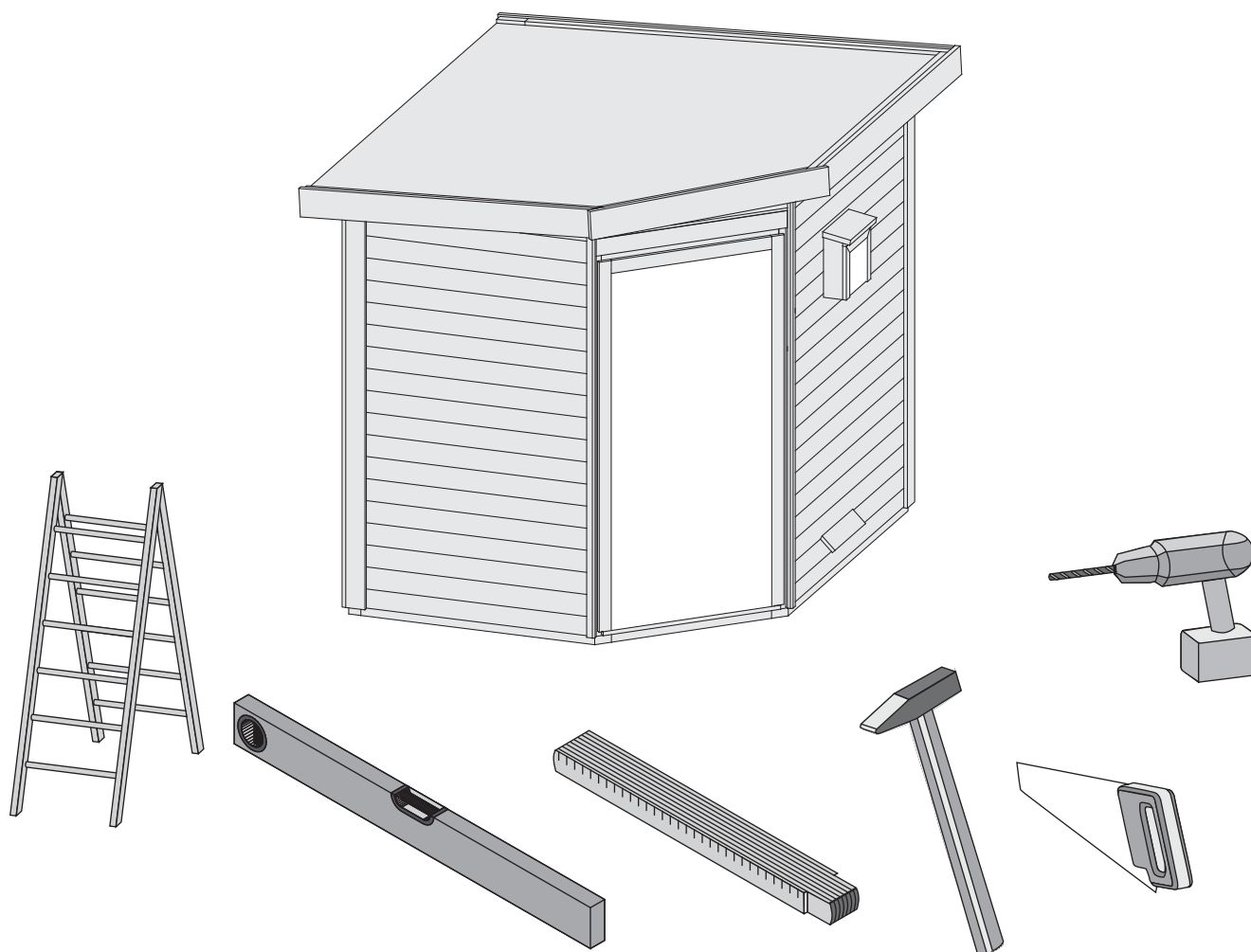

 **Aufbauanleitung**

 **Building Instructions**

 **notice de montage**

 **montagehandleiding**

 **Montagevejledning**

 **Instrucciones de construcción**

 **Istruzioni per il montaggio**

 **Montážní návod**



+49 421 38693 33



Vergleichen Sie zuerst die Material-liste mit Ihrem Paketinhalt! Bitte haben Sie Verständnis, dass Beanstandungen nur im nicht aufgebauten Zustand bearbeitet werden können!



Vergelijk eerst de lijst van materialen met de inhoud van uw pakket! Reclamaties kunnen alleen in behandeling worden genomen zolang de onderdelen nog niet zijn gemonteerd!



Confrontate questa distinta materiali prima con il contenuto del pacchetto! Vi preghiamo di comprendere che eventuali reclami possono essere accolti solo prima del montaggio!



First compare the list of materials with your package contents! Please understand that complaints can be processed in the non-built status only!



Start med at kontrollere materialelisten med indholdet af den leverede pakke! Vi gør venligst opmærksom på at reklamationer kun kan behandles for materialer som ikke er blevet bearbejdet!



Nejprve přezkontrolujte obsah balení podle materiálového listu! Mějte pochopení pro to, že případnou reklamaci se můžeme zabývat pouze tehdy, když díly nebudou smontované! Za pomoci tohoto seznamu můžete jednotlivé díly přiřadit k montážnímu návodu.



Commencez par comparer la liste du matériel avec le contenu de votre paquet! Sachez que nous traitons uniquement les réclamations concernant le matériel à l'état non monté!



En primer lugar, compare la lista de material con el contenido del paquete. Rogamos entienda que las reclamaciones sólo pueden ser tramitadas antes de montar el objeto!

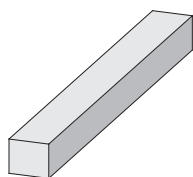
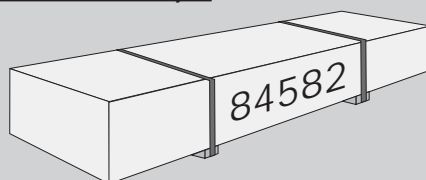

2 x B1	1920 x 20 x 3 mm	ID 20799
1 x B2	2156 x 90 x 16 mm	ID71514
2 x B3	800 x 45 x 18 mm	ID 24796
1 x B4	900 x 45 x 18 mm	ID 19543
1 x B5	1000 x 45 x 18 mm	ID 22033
2 x B6	1471 x 45 x 18 mm	ID 70636
1 x B7	1809 x 45 x 18 mm	ID 21831
5 x B8	2100 x 45 x 18 mm	ID 19547
2 x B9	2159 x 45 x 18 mm	ID 21483
1 x B10	300 x 95 x 18 mm	ID 19130
4 x B11	480 x 95 x 18 mm	ID 20930
4 x B12	565 x 95 x 18 mm	ID 15498
4 x B13	2100 x 95 x 18 mm	ID 11427
2 x B14	2300 x 95 x 18 mm	ID 16177
1 x B15	1227 x 90 x 19 mm	ID 20867
1 x B16	1810 x 90 x 19 mm	ID 20896
1 x B17	1210 x 140 x 26 mm	ID 36420
1 x B18	2250 x 140 x 26 mm	ID 50192
2 x B19	800 x 58 x 28 mm	ID 15493
3 x B20	2160 x 36 x 36 mm	ID 63004
3 x B21	1890 x 60 x 40 mm	ID 28536
1 x B22	2260 x 60 x 40 mm	ID 70614

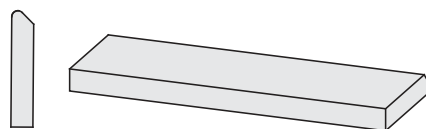

2 x A1	400 x 95 x 18 mm	ID 27167
--------	------------------	----------

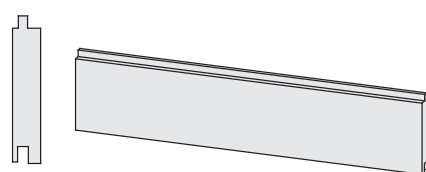

21 x M1	2195 x 96 x 19 mm	ID 65729
30 x M2	2240 x 96 x 19 mm	ID 42283

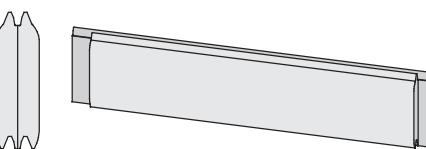

2 x W1	972 x 121 x 38 mm	ID 70417
18 x W2	1193 x 121 x 38 mm	ID 70384
19 x W3	1543 x 121 x 38 mm	ID 70638
18 x W4	1881 x 121 x 38 mm	ID 21429
18 x W5	2231 x 121 x 38 mm	ID 21463

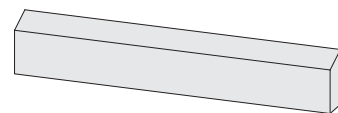

4 x F1	245 x 36 x 18 mm	ID 70421
4 x F2	1916 x 36 x 36 mm	ID 21814

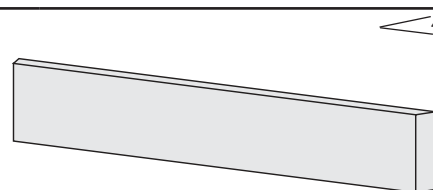

1 x R1	1470 x 140 x 26 mm	ID 70397
1 x R2	1820 x 140 x 26 mm	ID 70399

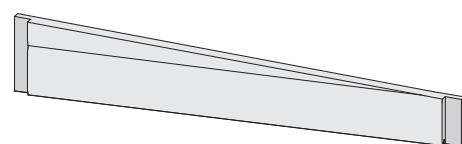

1 x G1	1193 x 165 x 38 mm	ID 70415
1 x G2	1881 x 200 x 38 mm	ID 70416

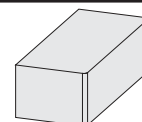

2 x A2	60 x 36 x 36 mm	ID 5512
--------	-----------------	---------

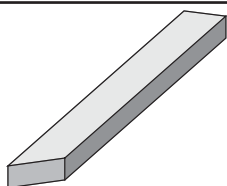

1 x C1	1216 x 60 x 40 mm	ID 70403
1 x C2	1626 x 60 x 40 mm	ID 70634

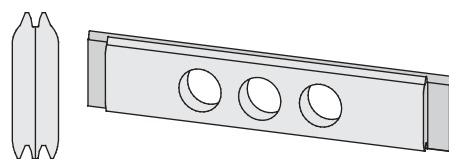

1 x W6	1543 x 121 x 38 mm	ID 70641
--------	--------------------	----------

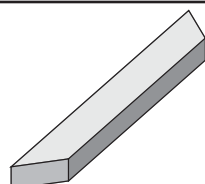

1 x C3	932 x 60 x 40 mm	ID 70414
--------	------------------	----------

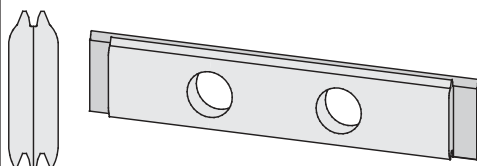

1 x W7	2231 x 121 x 38 mm	ID 21866
--------	--------------------	----------

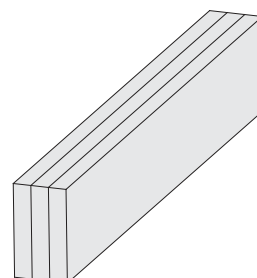

4 x P1	150 x 95 x 54 mm	ID 63278
2 x P2	2193 x 95 x 54 mm	ID 70617

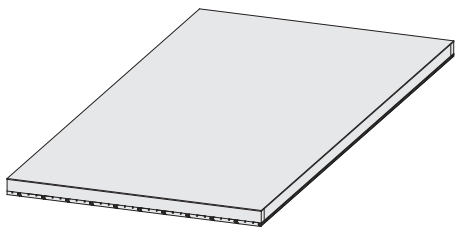

1 x N1 | 1839 x 350 x 57 mm | ID 53731

1 x N2 | 1839 x 918 x 57 mm | ID 70427

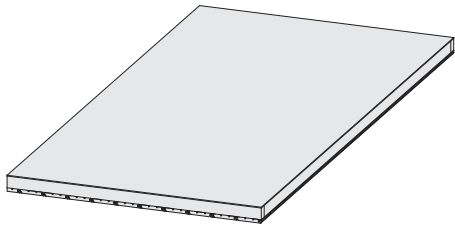

1 x N3 | 1839 x 918 x 55 mm | ID 21121

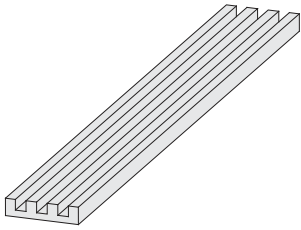

1 x E1 | 1820 x 110 x 26 mm | ID 26480

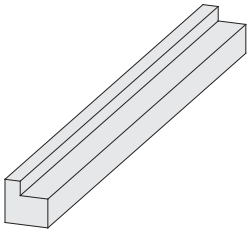

2 x E2 | 555 x 45 x 45 mm | ID 40301

3 x E3 | 1100 x 45 x 45 mm | ID 40302

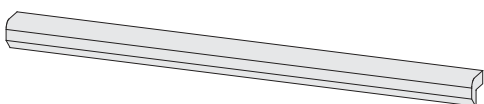

2 x E4 | 2165 x 38 x 38 mm | ID 70424

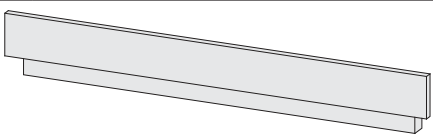

1 x E5 | 970 x 127 x 54 mm | ID 70422

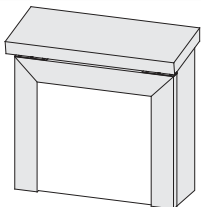

1 x H1 | 340 x 318 x 157 mm | ID 63452

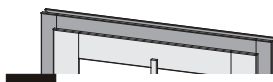

Siehe Türpaket

Opmerking Door Package

Note Door Package

Remarque Package porte

Nota Paquete Puerta

Nota Door Package

Poznámka Door balíček



Abbildung ähnlich

similar picture

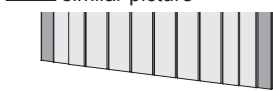

1 x D1 | 1820 x 940 x 38 mm

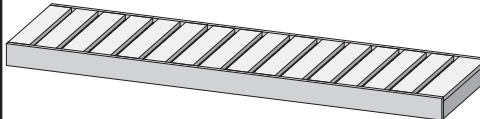

1 x L1 | 1227 x 550 x 90 mm | ID 21763

2 x L2 | 2156 x 550 x 90 mm | ID 52068

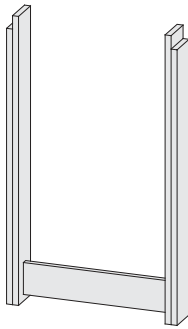

1 x L3 | 860 x 512 x 95 mm | ID 65739

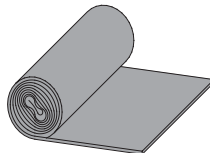

7,5 m² | ID 3710

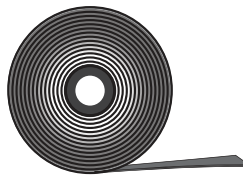

10 m | ID 14025

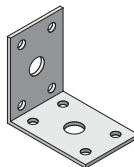

8x | ID 21292

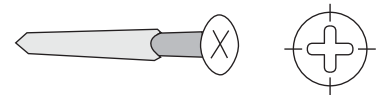

80 x	4 x 30 mm	ID 3686
150 x	4 x 35 mm	ID 3687
350 x	4 x 40 mm	ID 21925
120 x	4 x 50 mm	ID 3688
30 x	4 x 70 mm	ID 3689
25 x	4,5 x 80 mm	ID 9204
20 x	6 x 60 mm	ID 14014
20 x	6 x 80 mm	ID 47558
120 x	6 x 90 mm	ID 26715
20 x	6 x 100 mm	ID 11749



3 x S1 | ID 42172



500 x | ID 5621



300 x | ID 3948



1 x | ID 71504

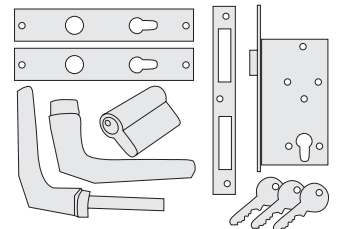

1 x | ID 15979

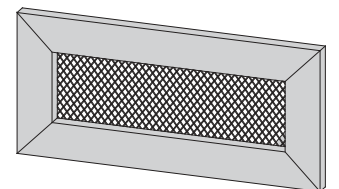

2 x | ID 86726

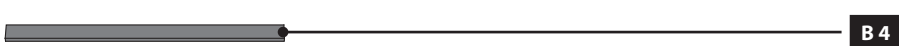
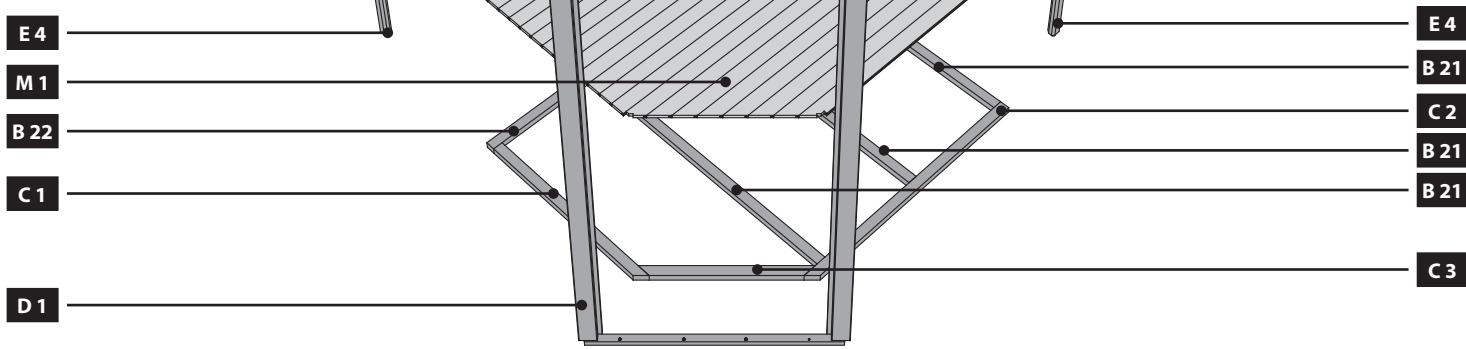
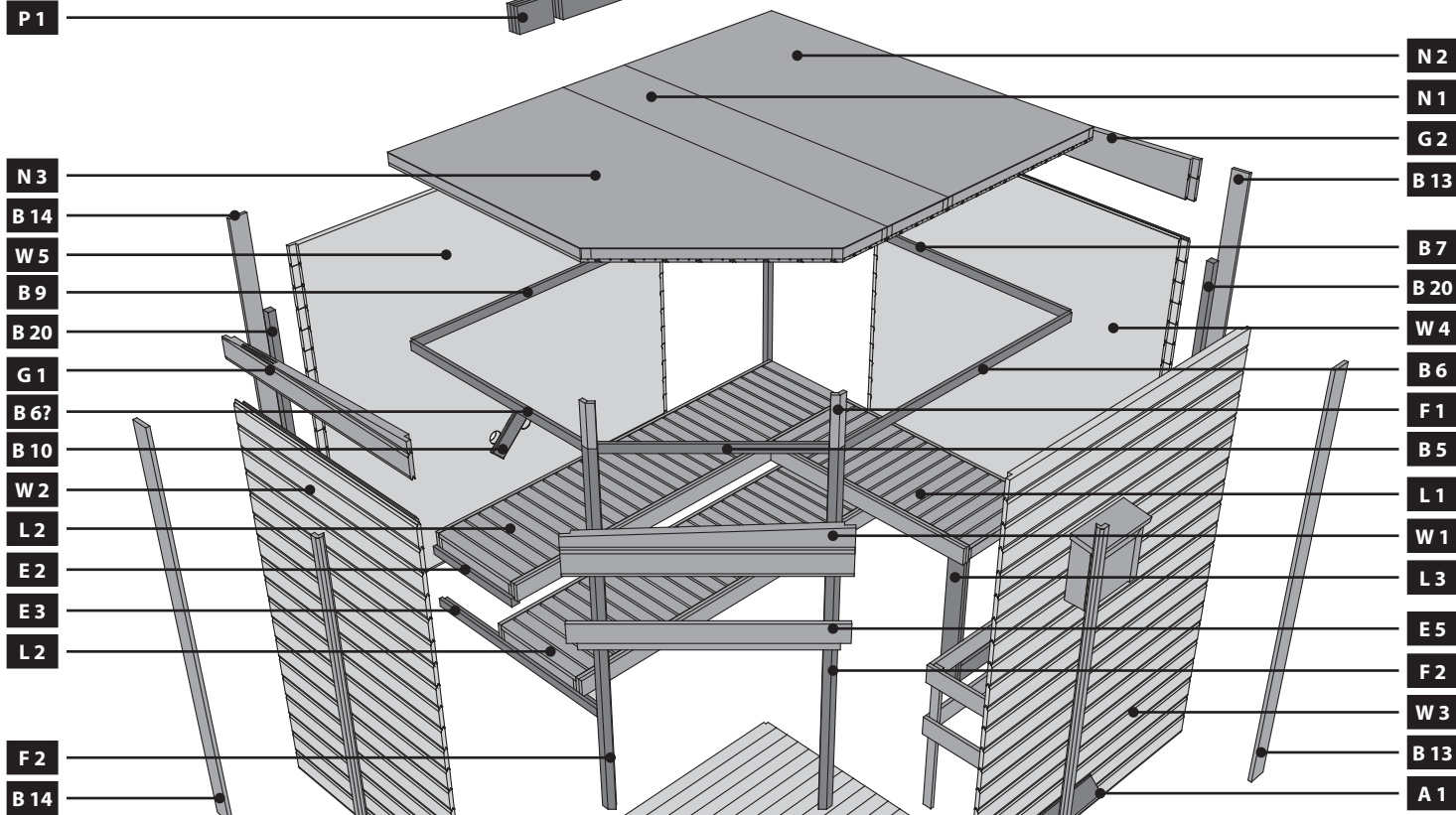
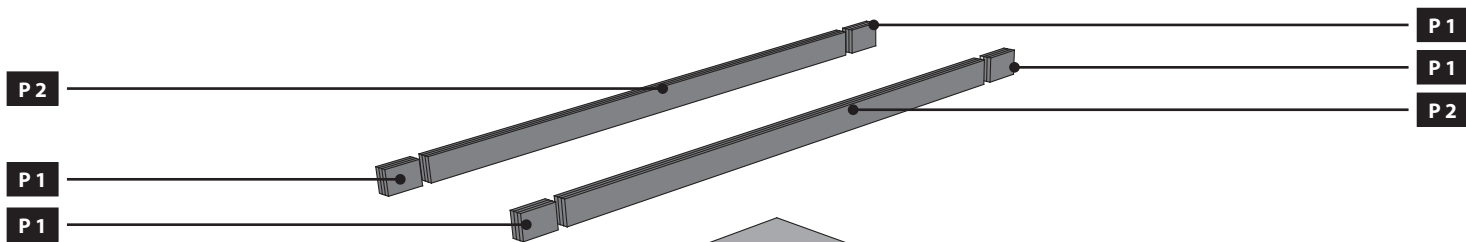
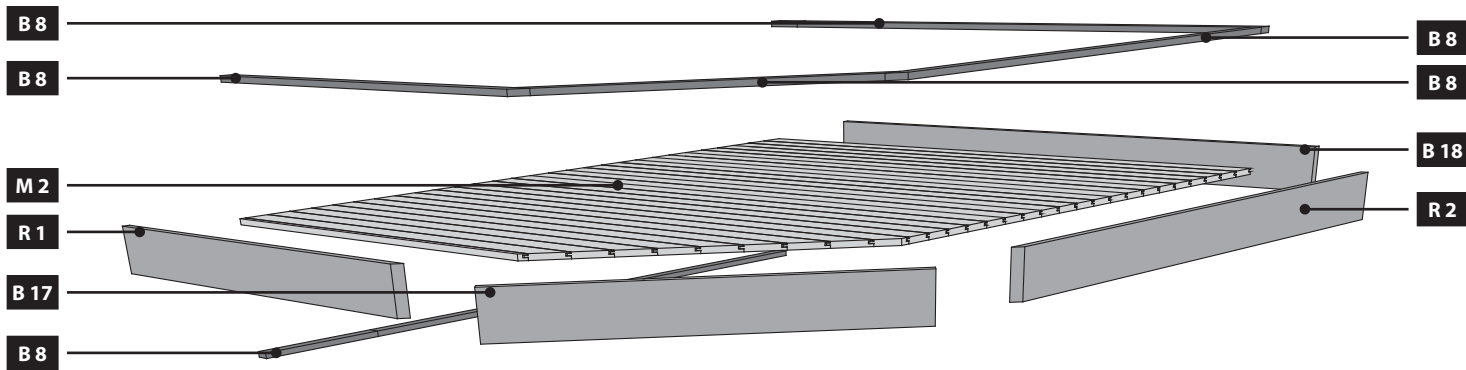

01 3x

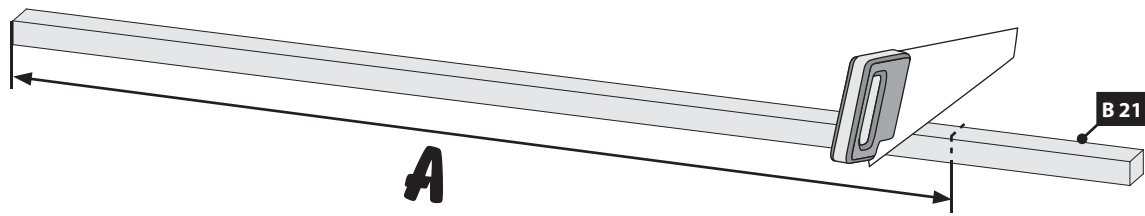

02

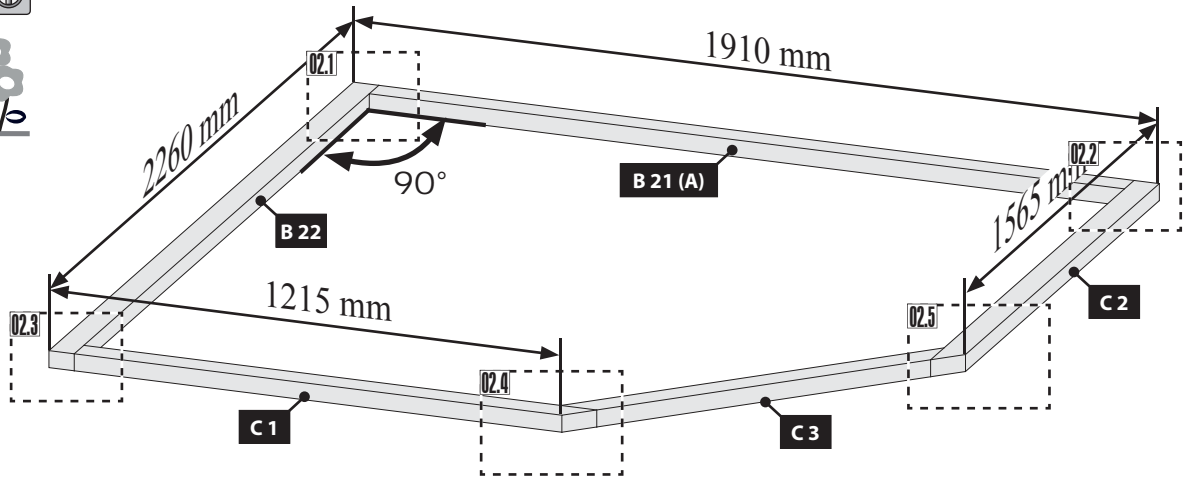
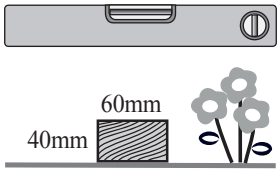

02.1

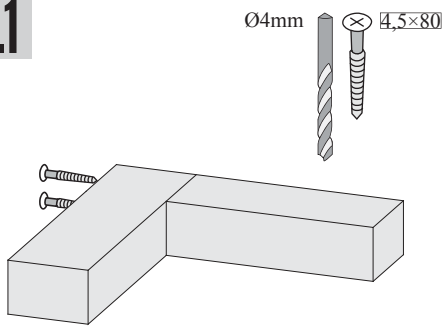

02.2

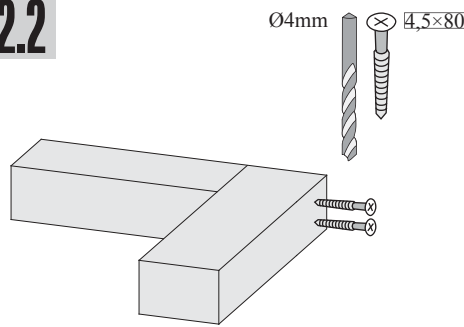

02.3

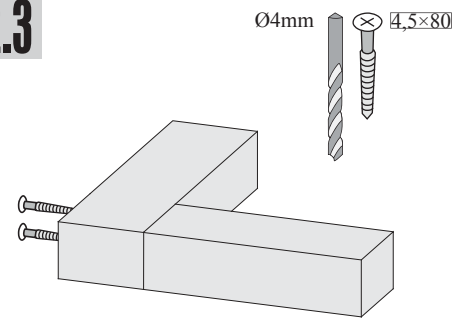

02.4

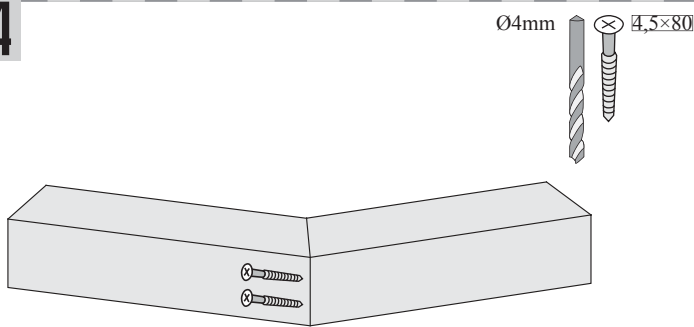

02.5

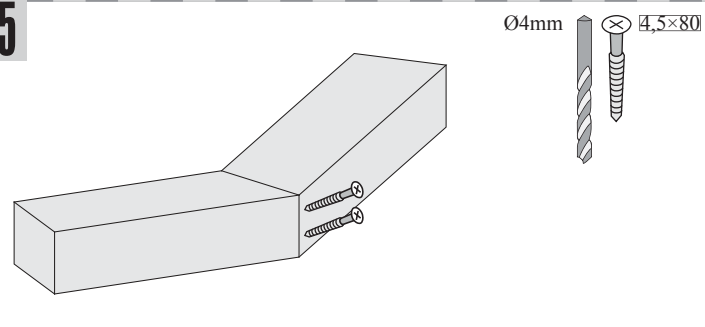

03



!!! A=B=C !!!

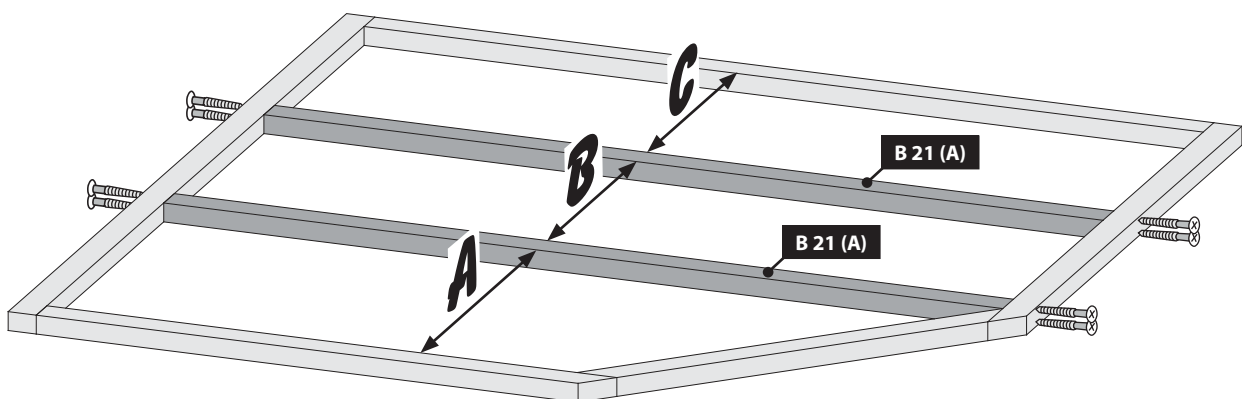
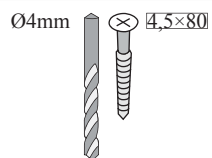

04

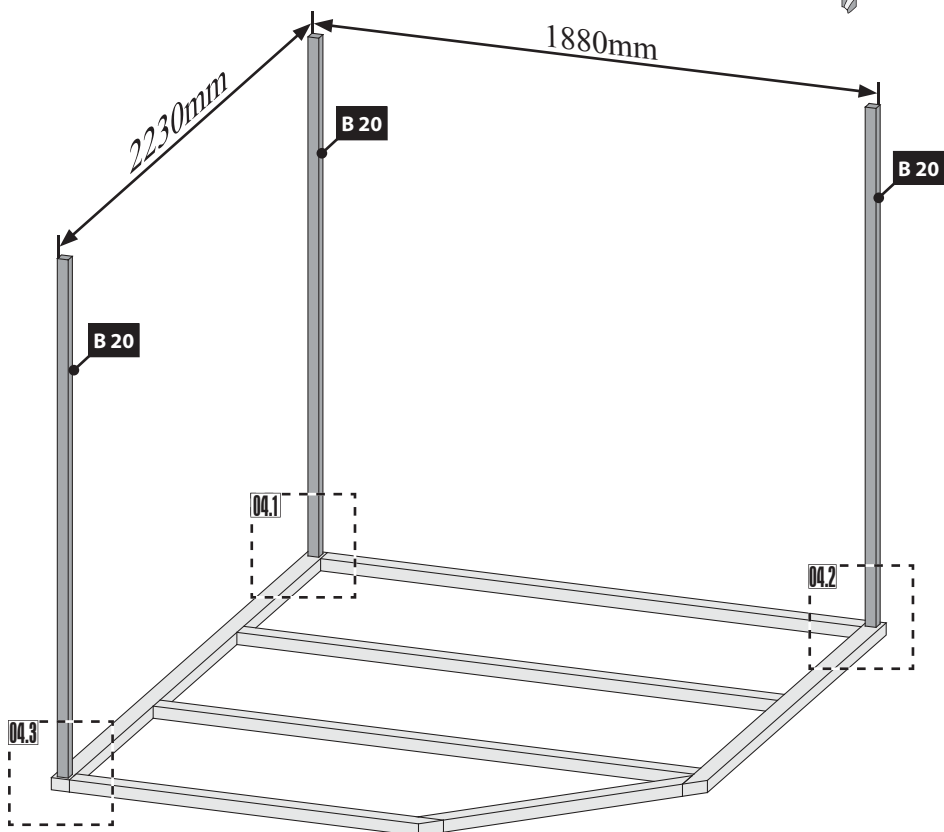
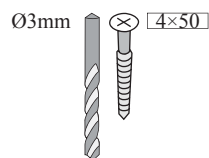

04.1

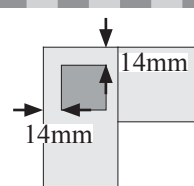
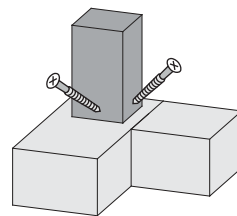

04.2

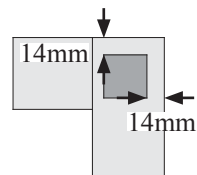
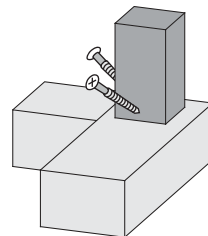

04.3

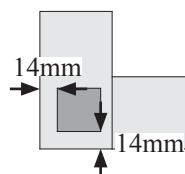
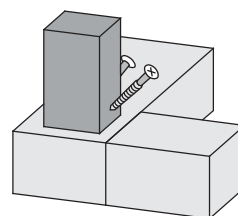

05

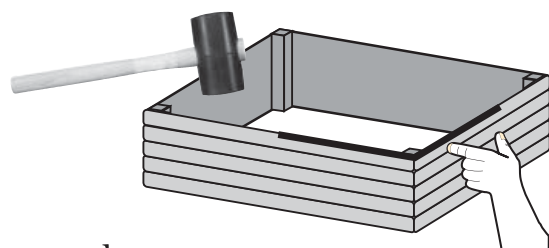

Bündig!
Affleurement!
Gelijk!
Aras!
Flush!
Combacia!
Flush!

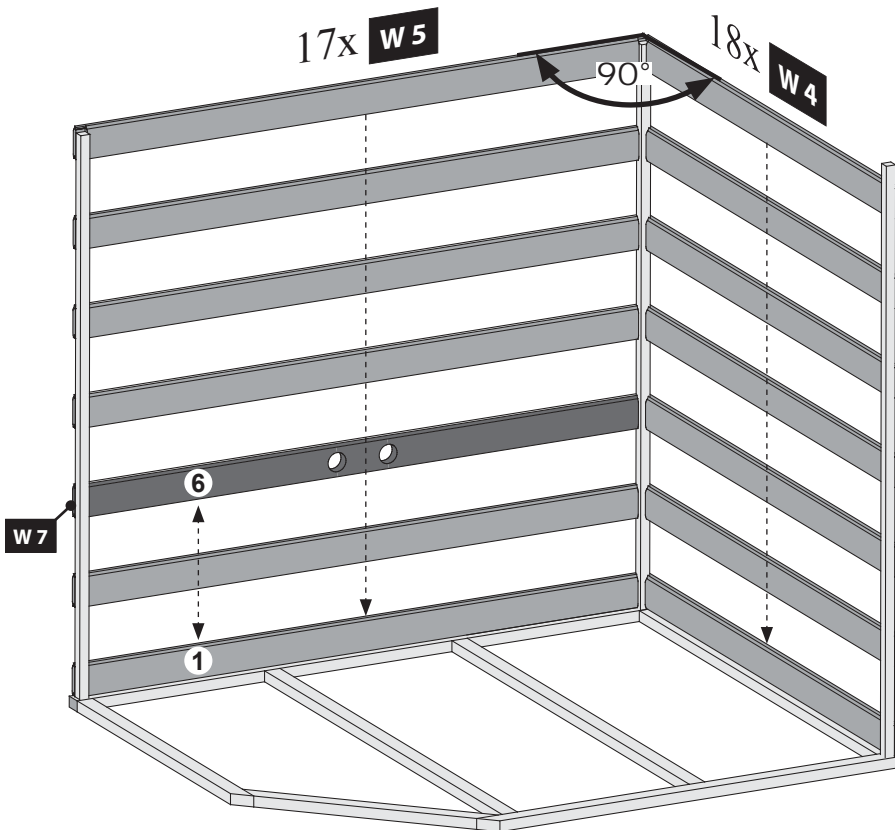
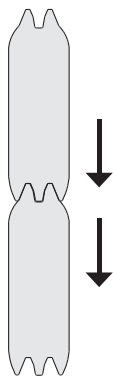

- Leim
- Colle
- Glue
- Lijm
- Pegamento
- Colla
- Klíh

06

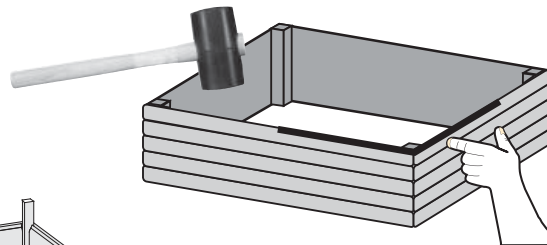
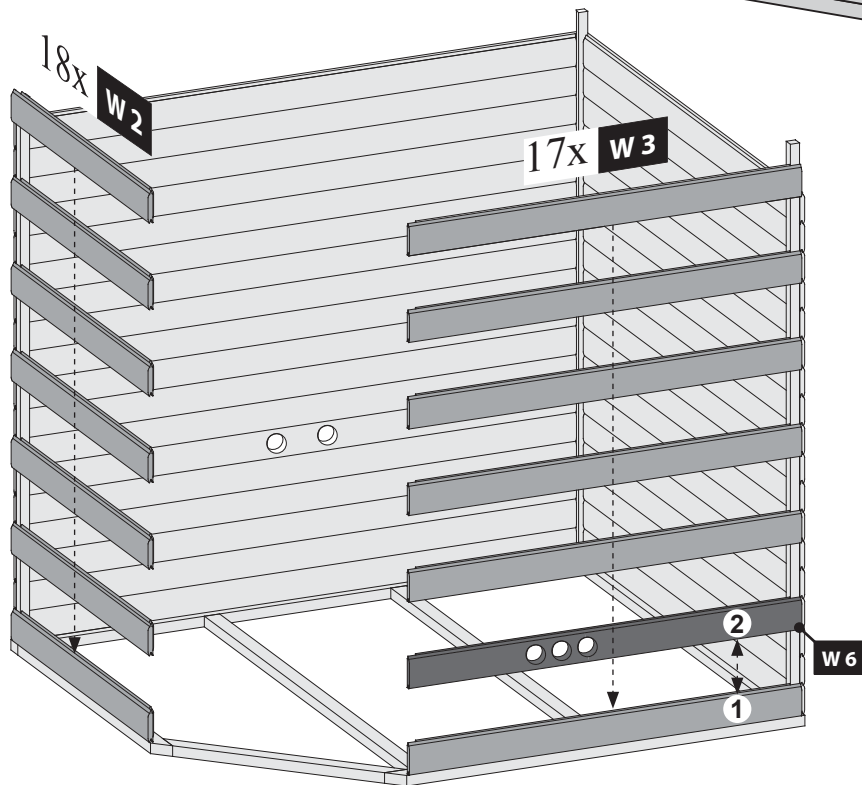
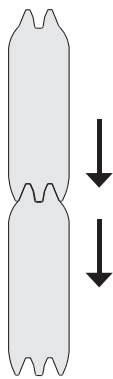

Bündig!
Affileurement!
Gelijk!
Aras!
Flush!
Combacia!
Flush!

Leim
 Colle
 Glue
 Lijm
 Pegamento
 Colla
 Klijh

07

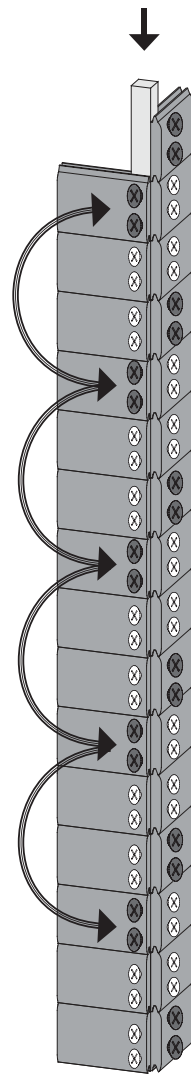
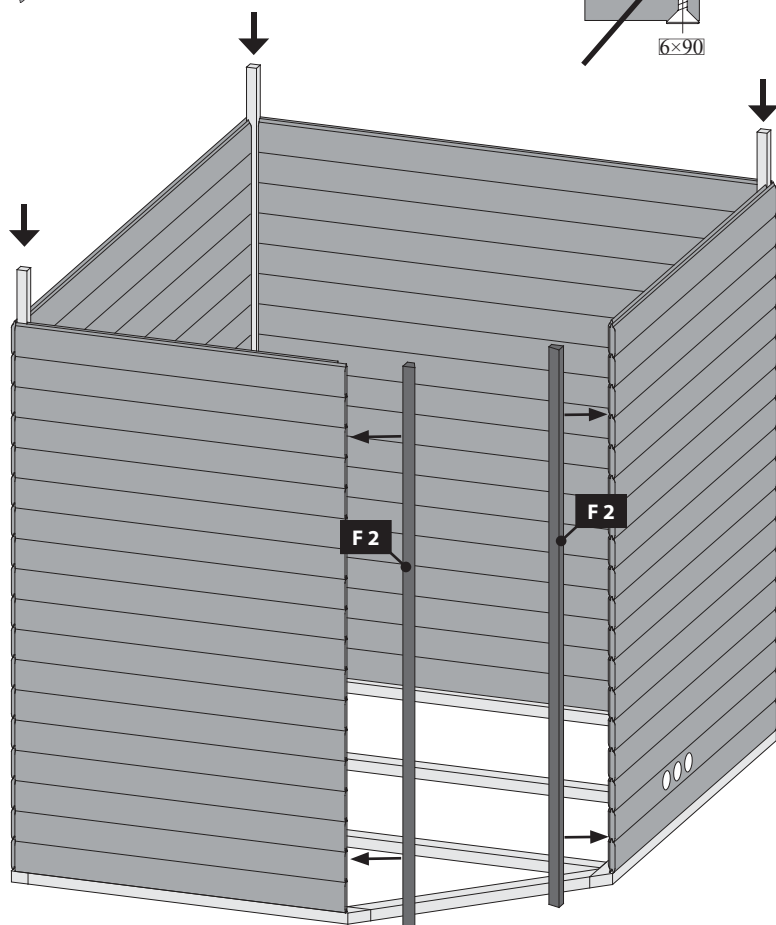
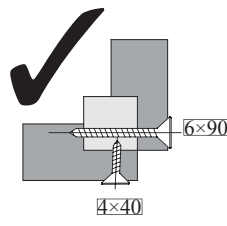
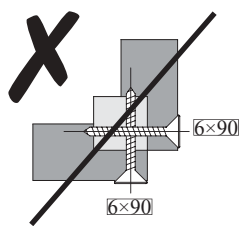
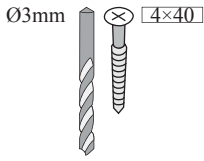
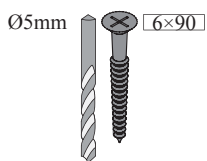

08

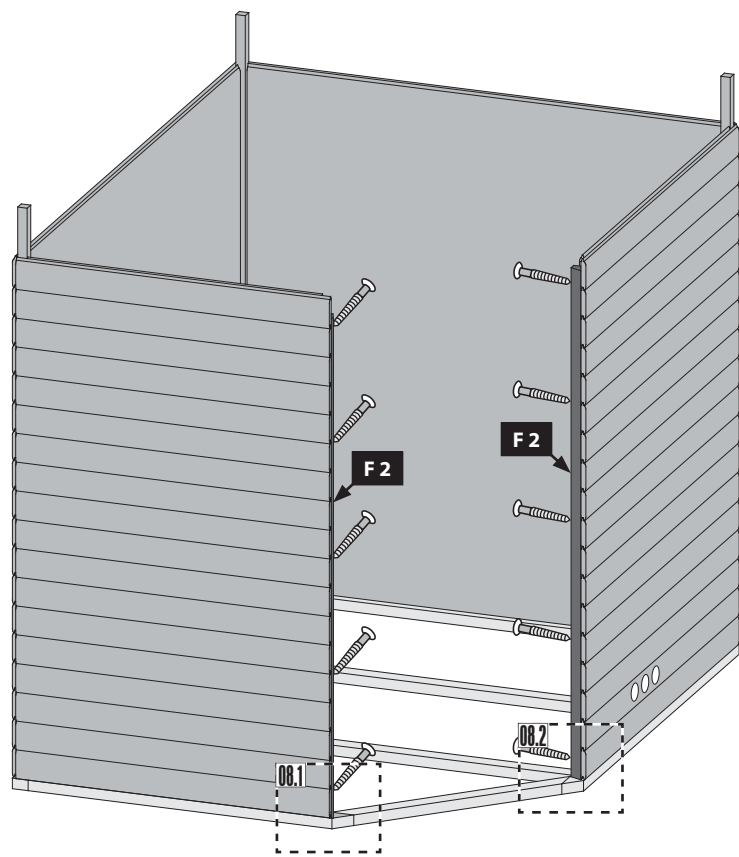

08.1

Ø3mm 4x50

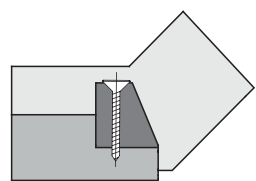
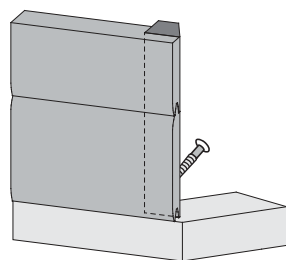

08.2

Ø3mm 4x50

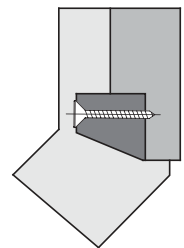
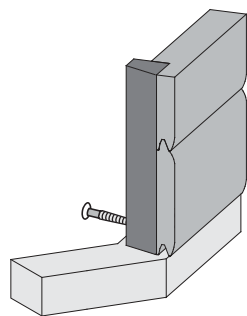

09

Ø3mm 4x35

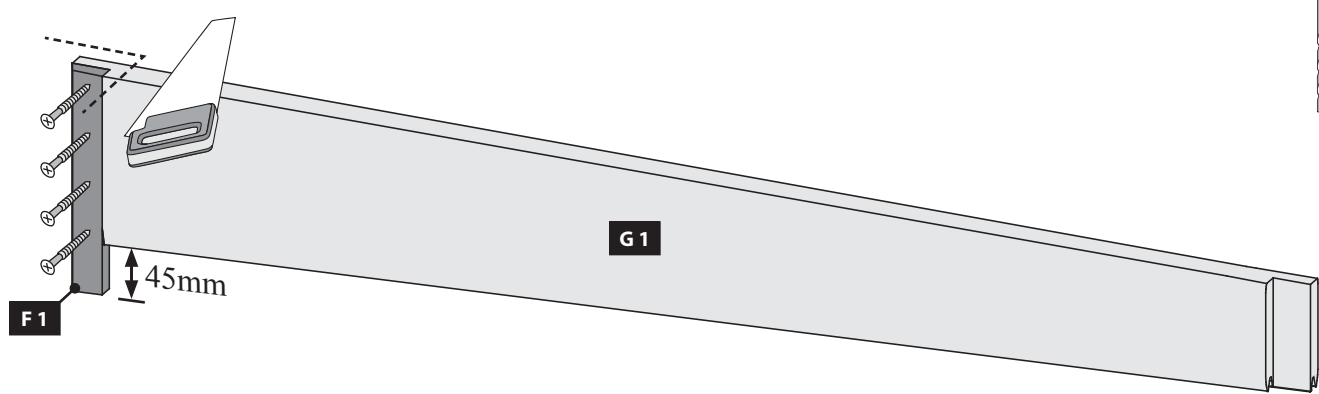

10

Ø3mm 4x35

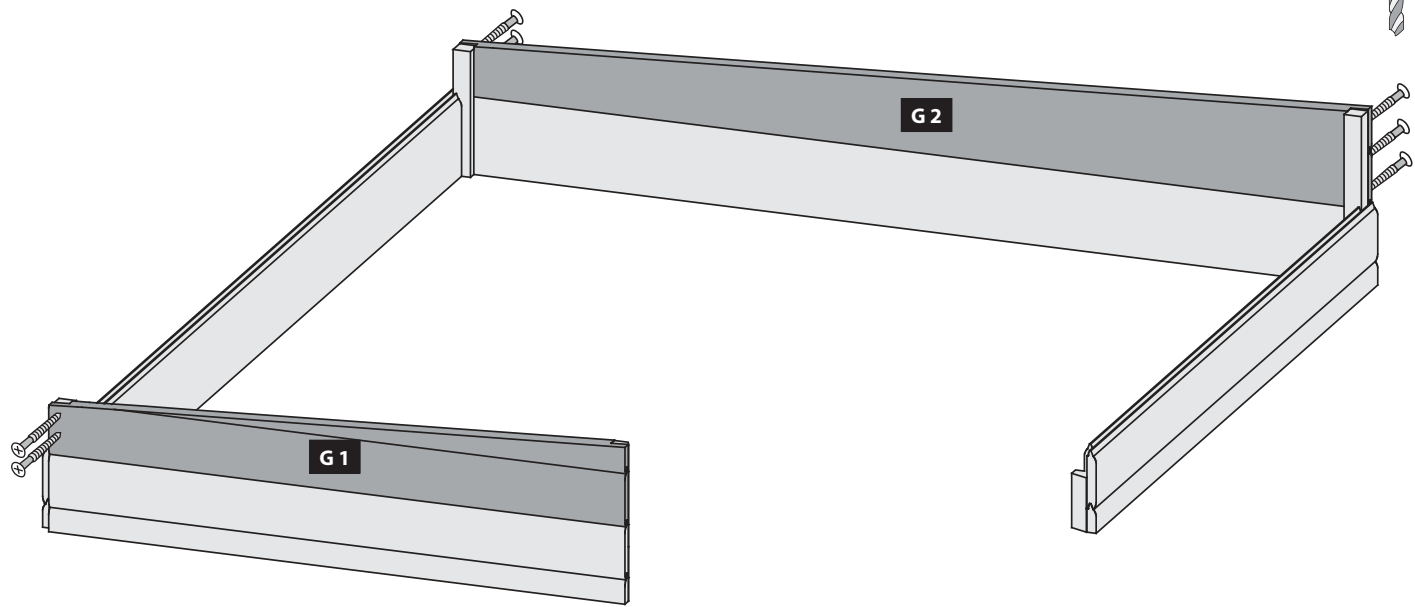

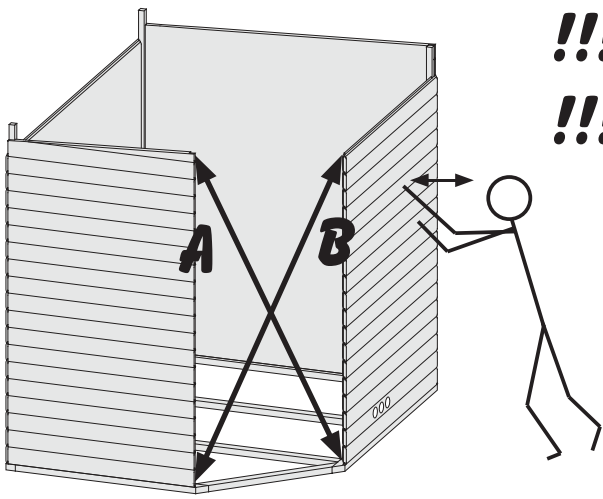

!!! A=B !!!
!!! C=D !!!

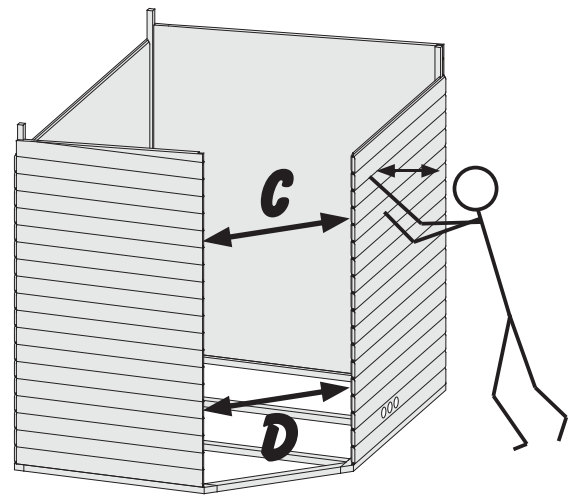

11

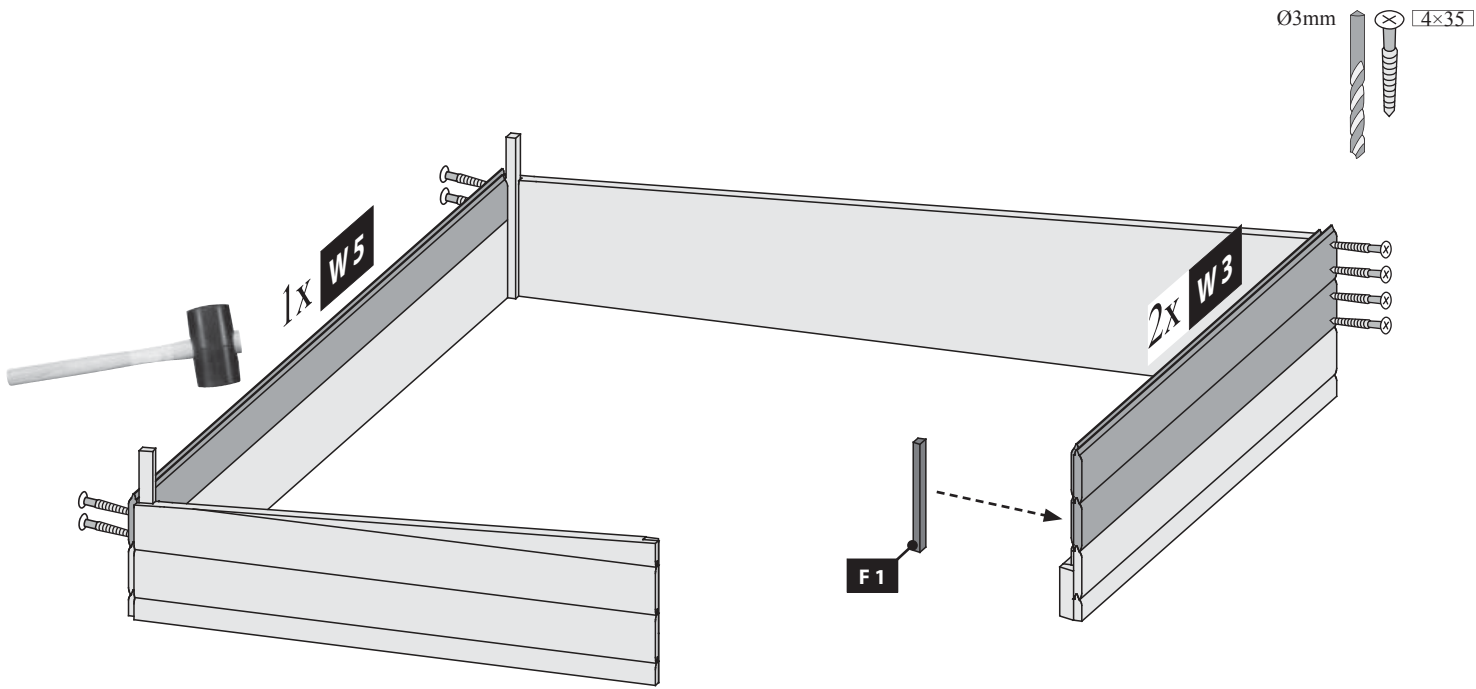

12



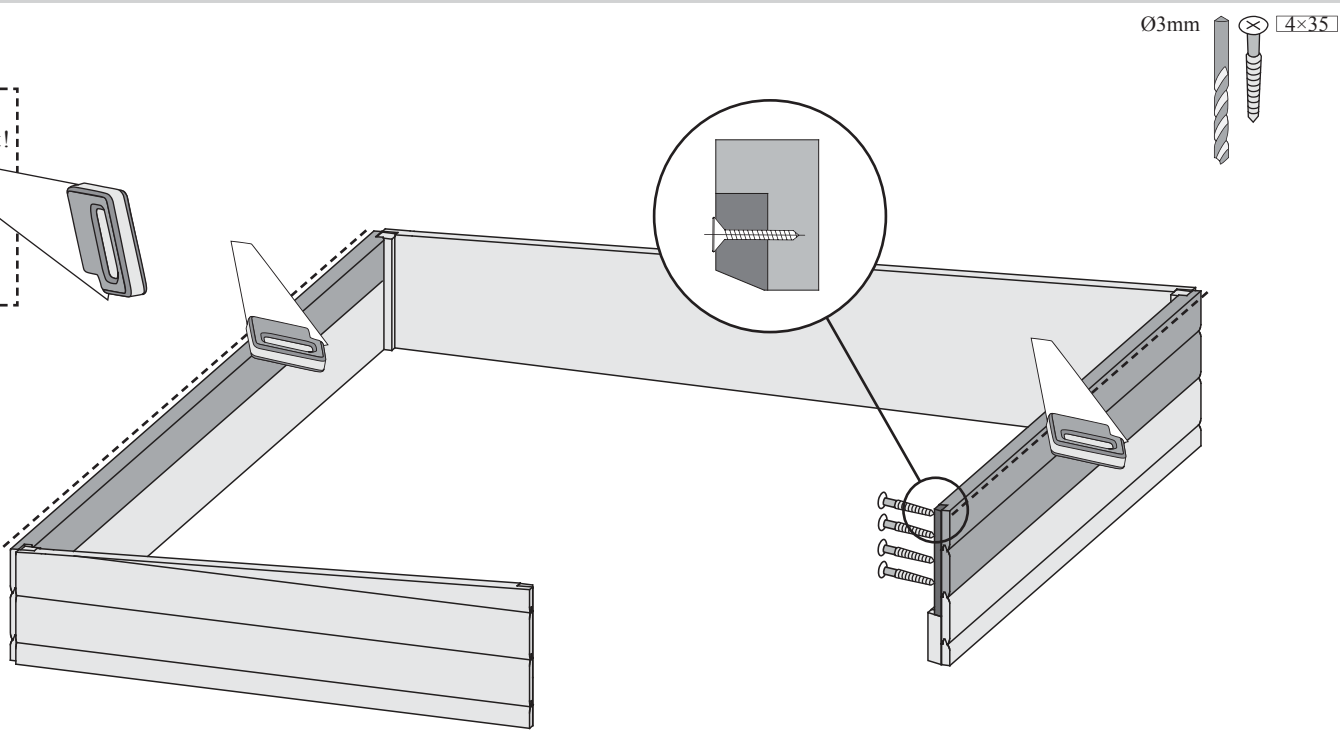

Bündig!
 Affleurement!
 Gelijk!
 Aras!
 Flush!
 Combacia!
 Flush!

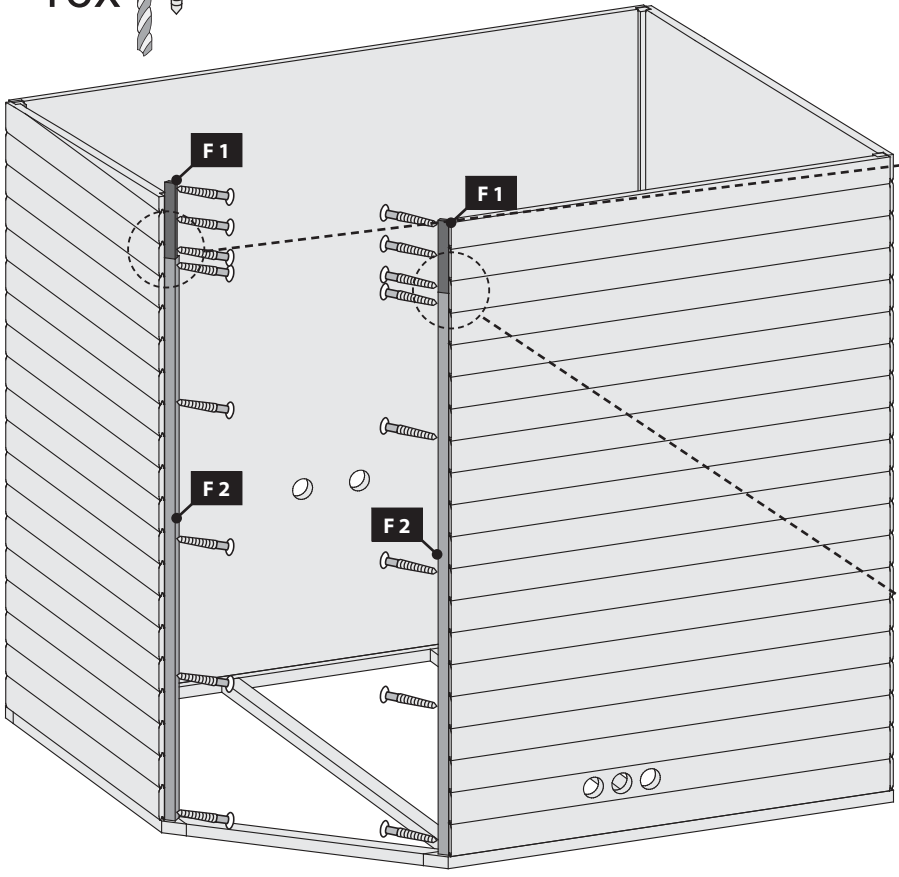

Ø3 mm 4x40

16x



-  Bündig!
-  Flush!
-  Affleurement!
-  Gelijk!
-  I flugt!
-  Aras!
-  Combacia!
-  Stejný!

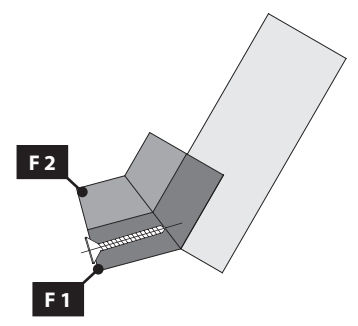
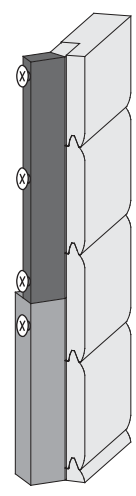
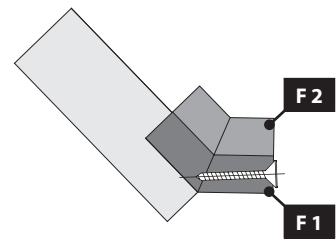
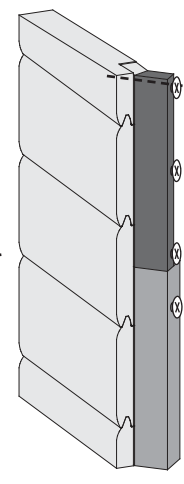

Ø3 mm 4x40

4x

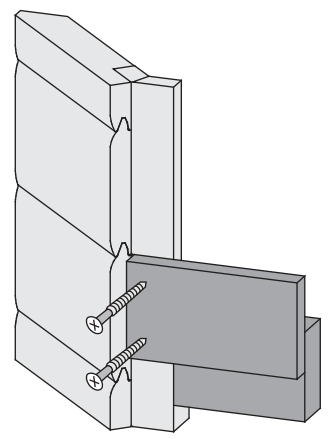
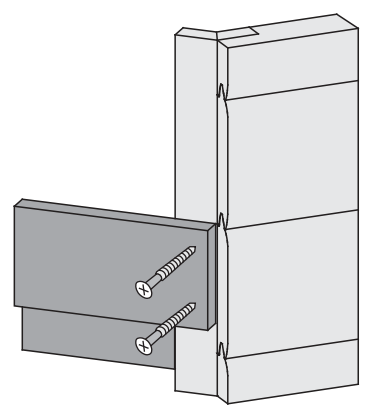
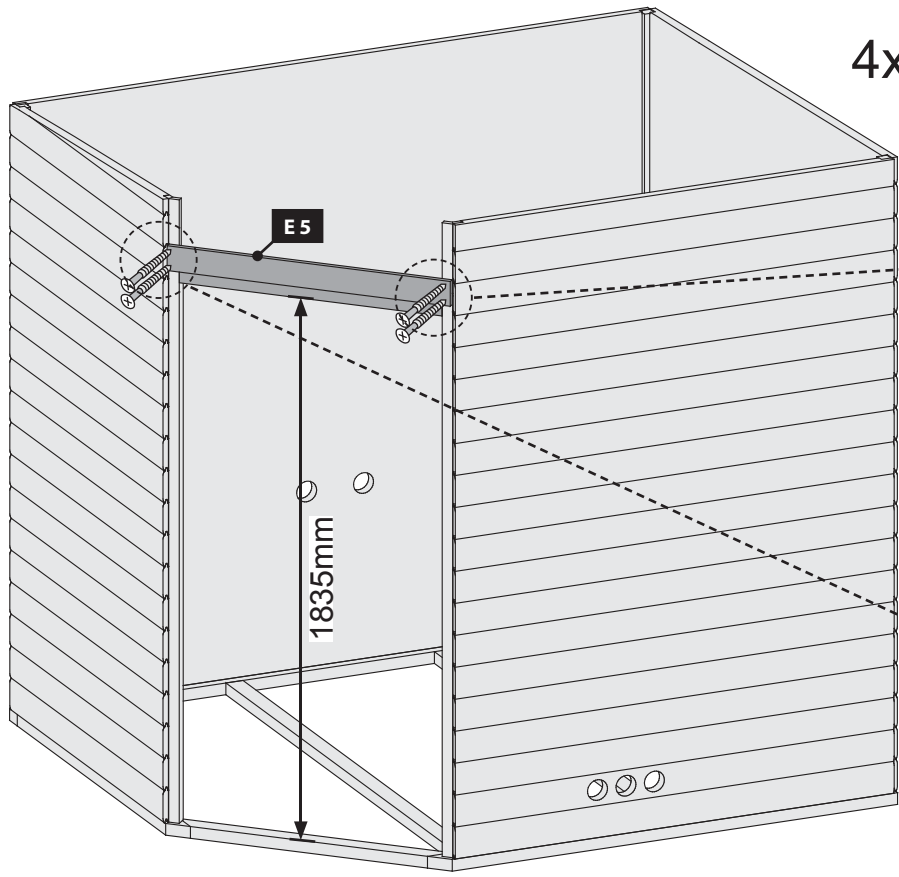

15

Ø3mm 4x40

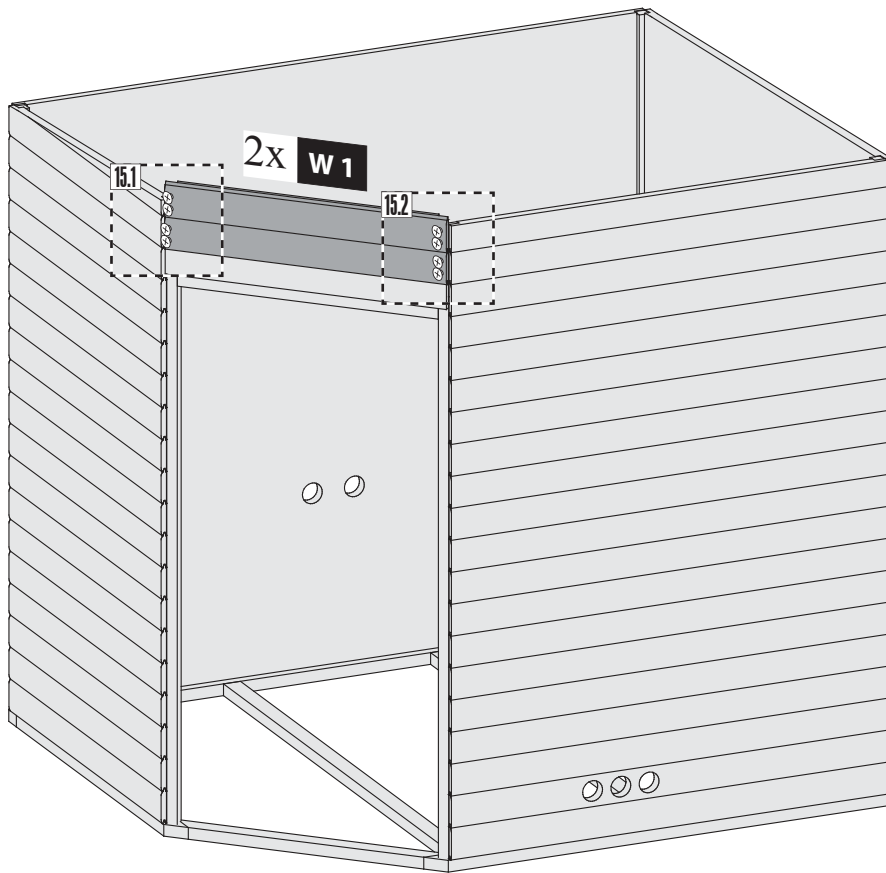
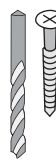

15.1

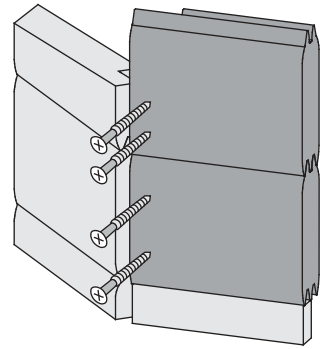

15.2

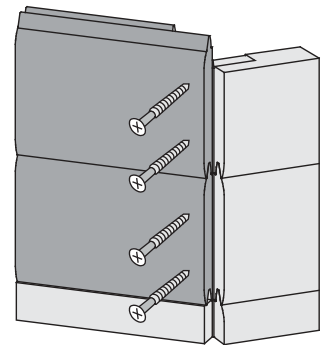

Bündig!
Affleurement!
Gelijk!
Aras!
Flush!
Combacia!
Flush!

16

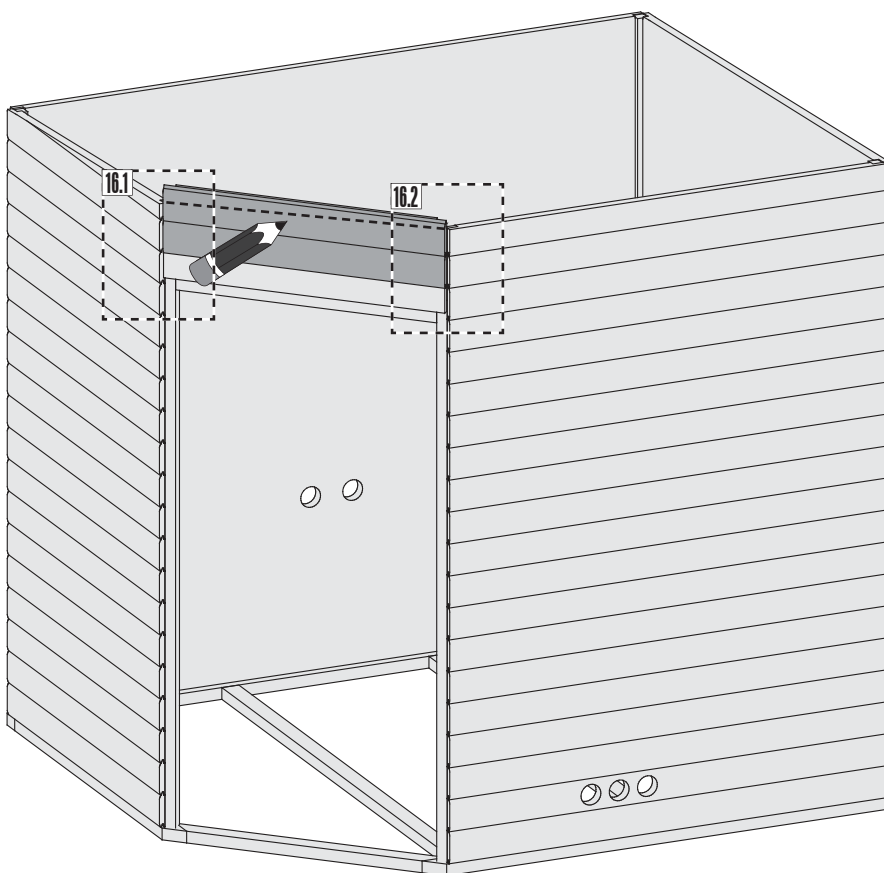
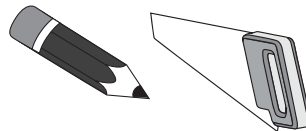

16.1

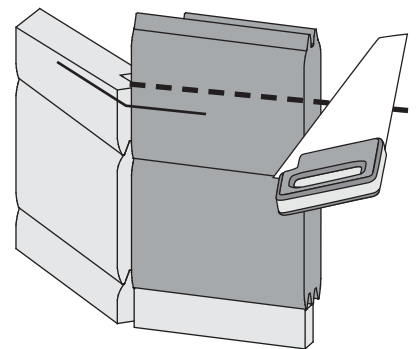

16.2

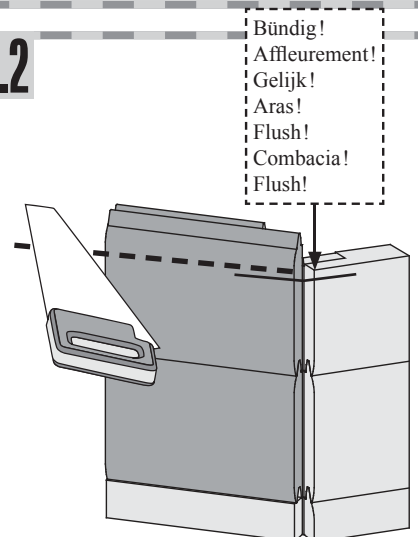

Bündig!
Affleurement!
Gelijk!
Aras!
Flush!
Combacia!
Flush!

17

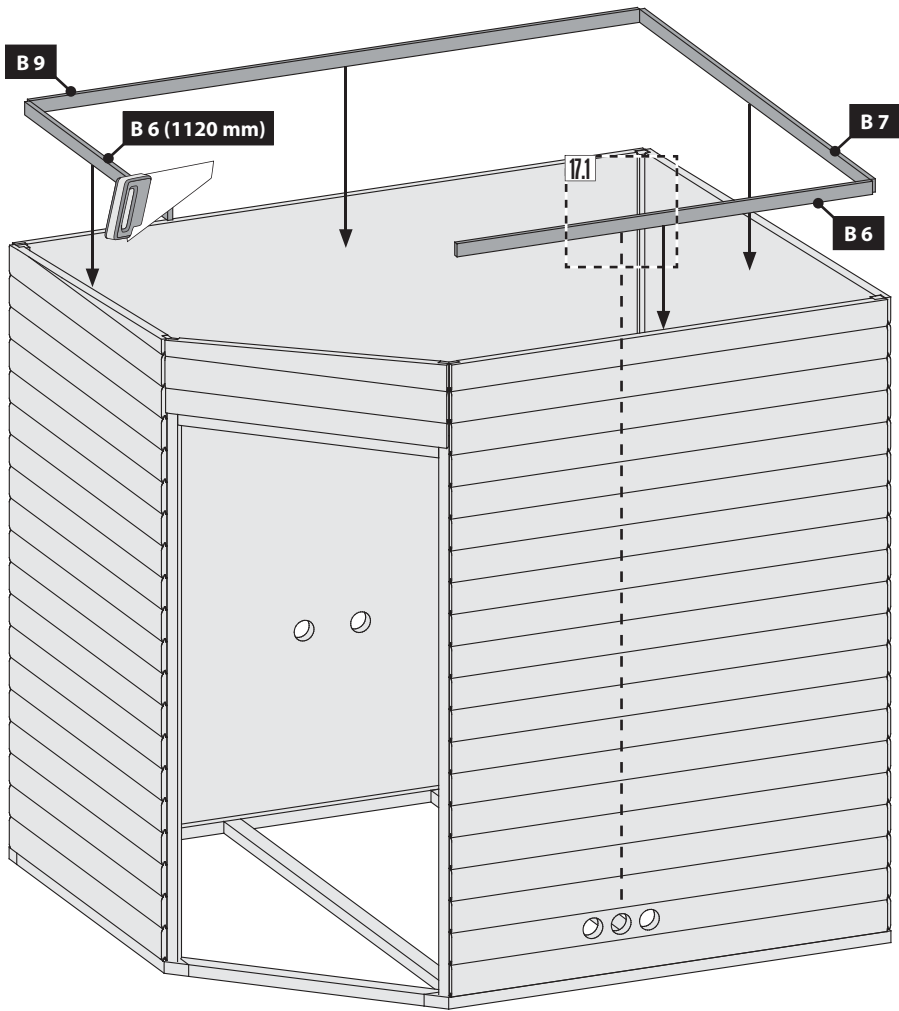

17.1

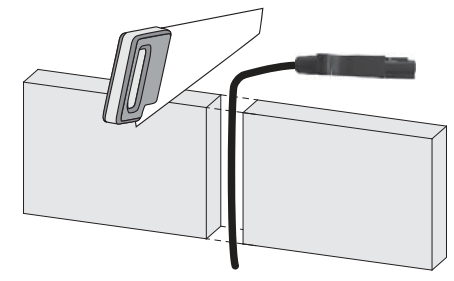

18

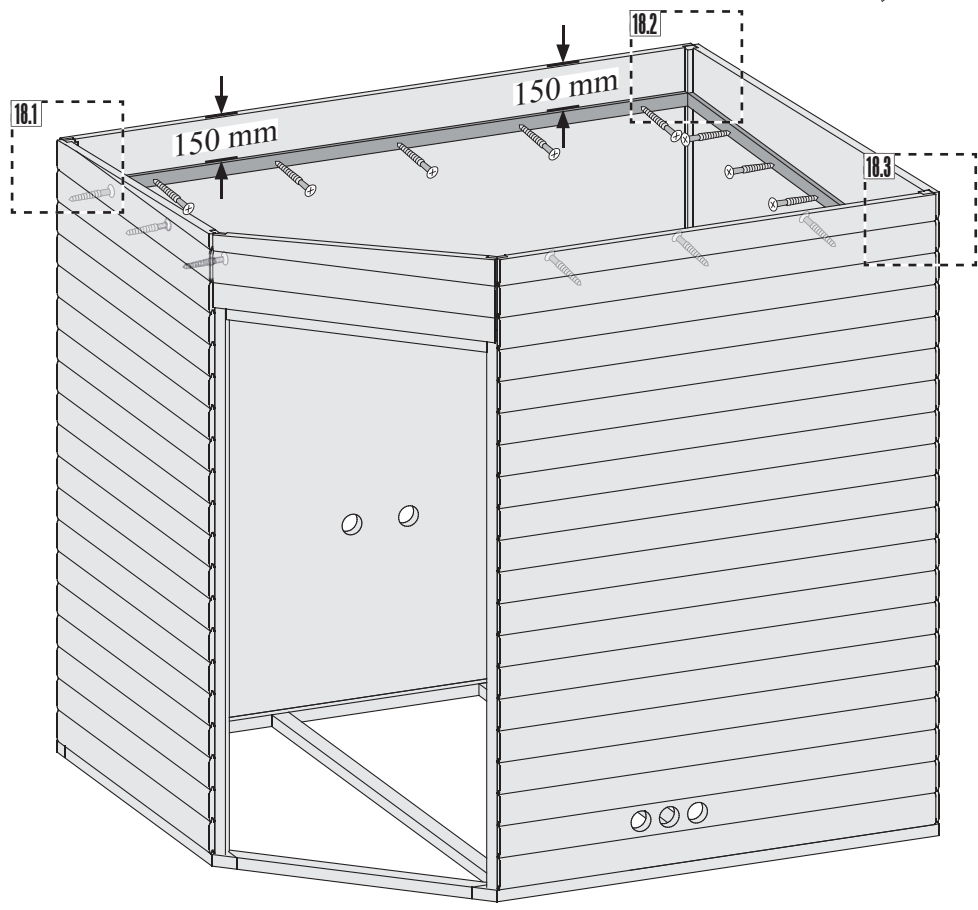
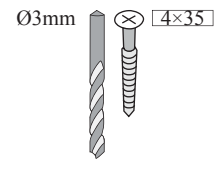

18.1

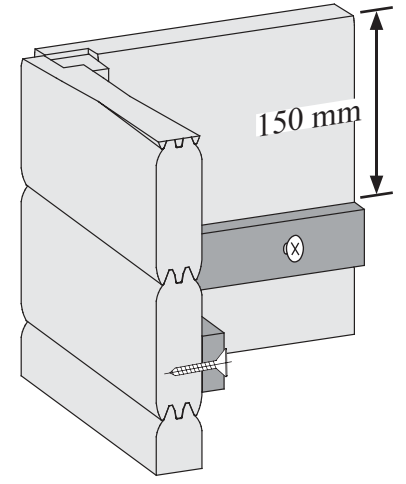

18.2

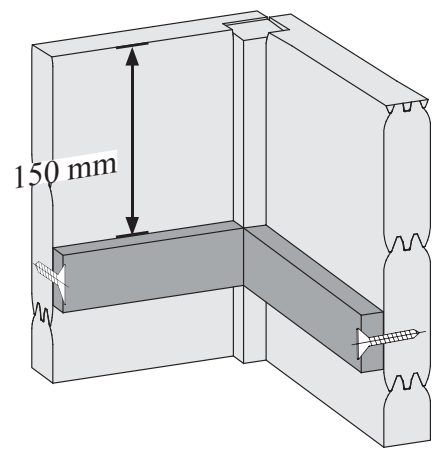

18.3

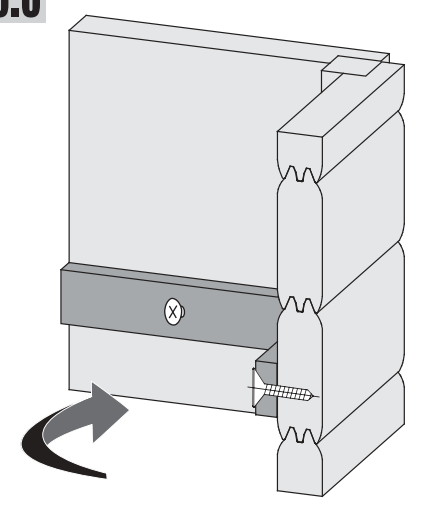

19

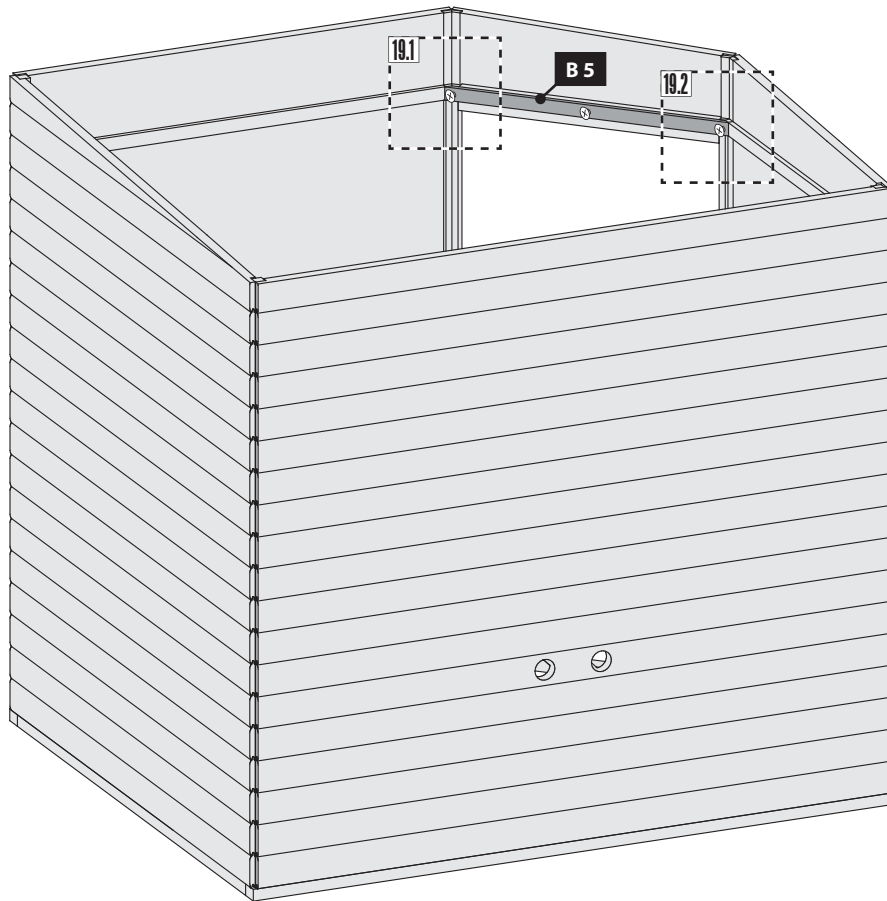
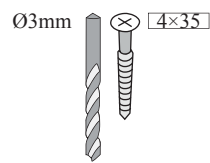
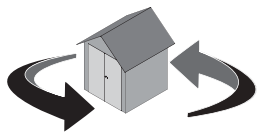

19.1

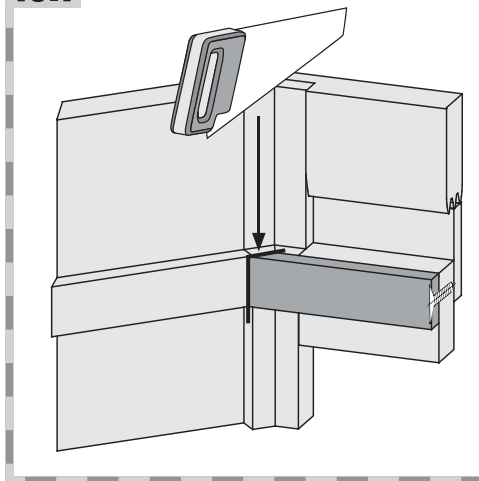

19.2

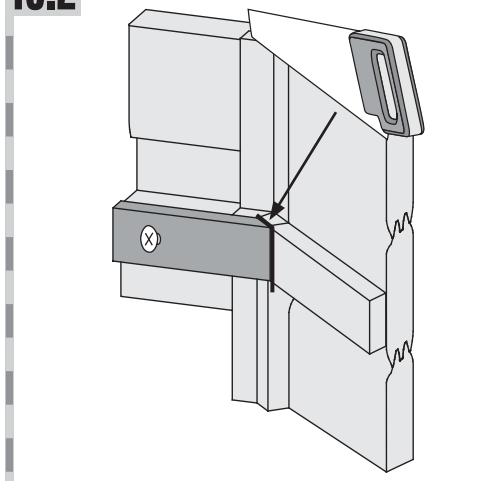

20

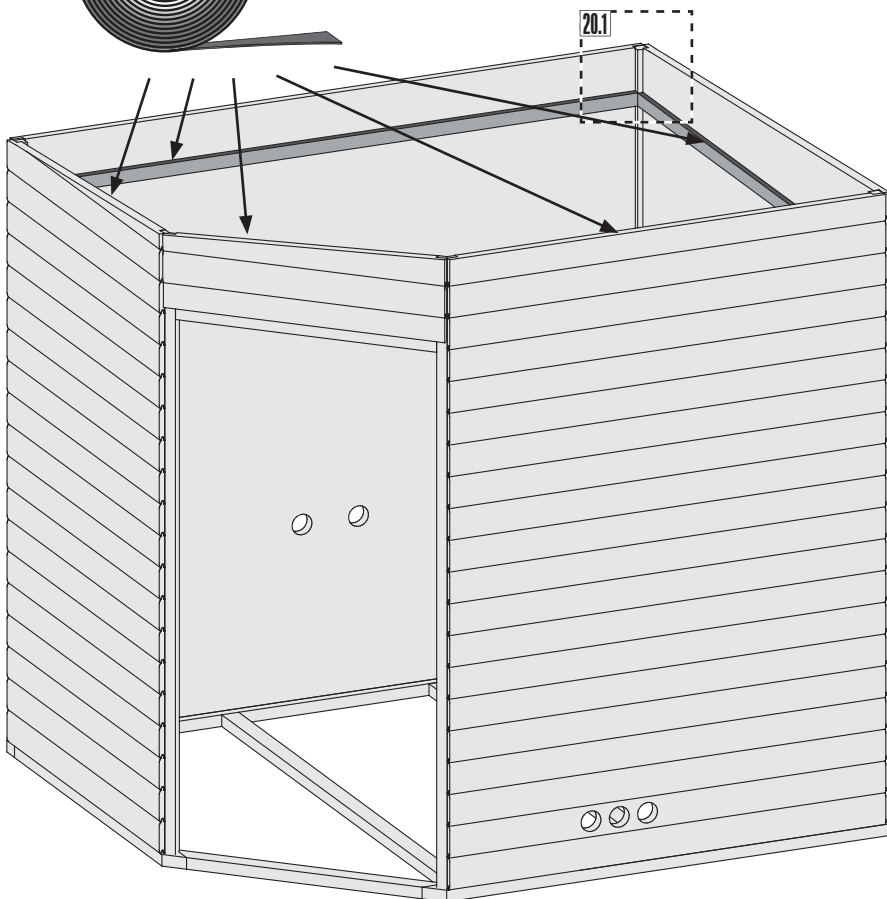

20.1-1

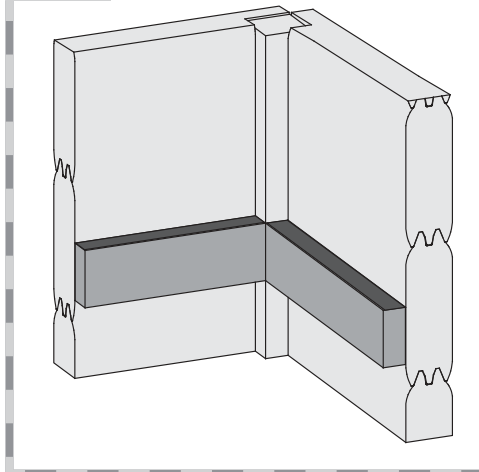

20.1-2

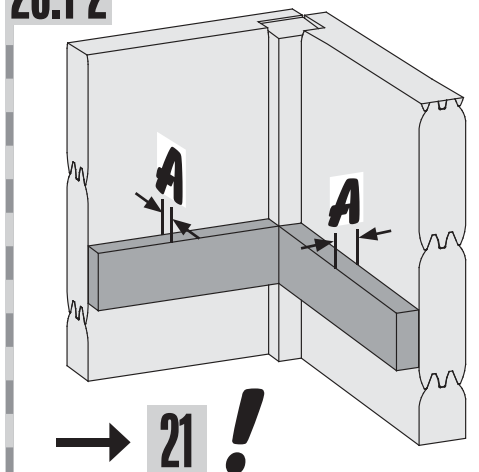

→ 21 !

21

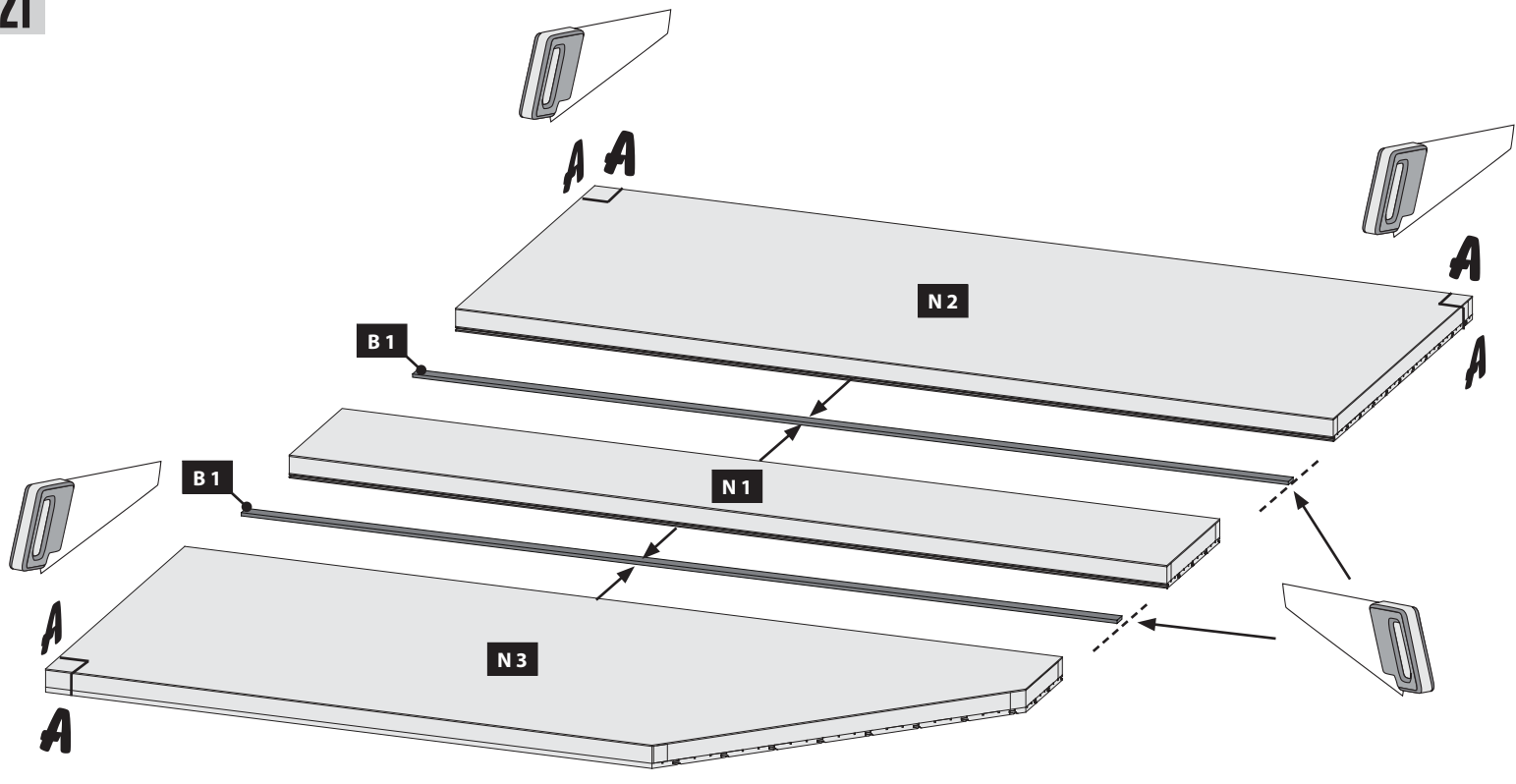

22

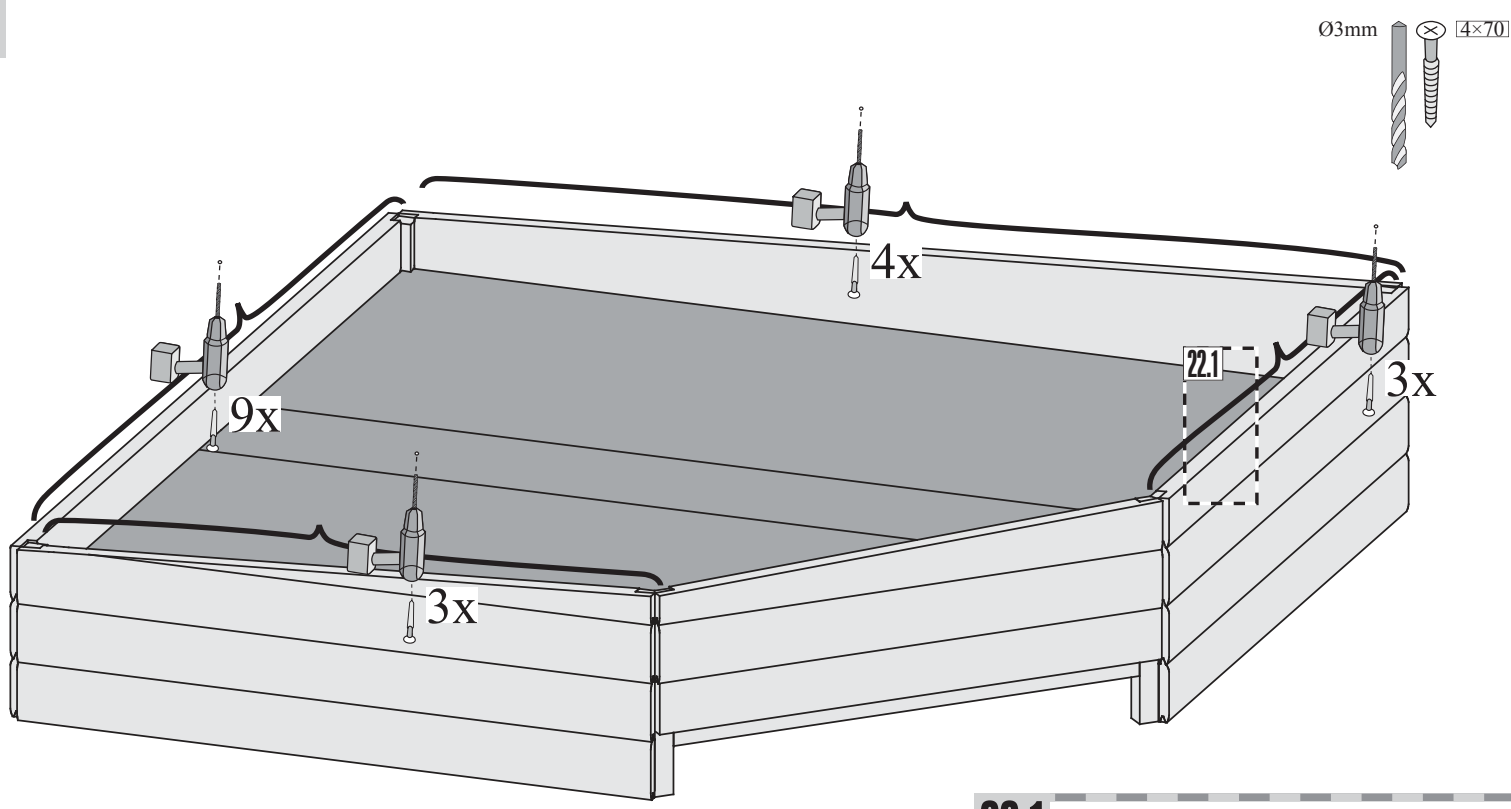

22.1

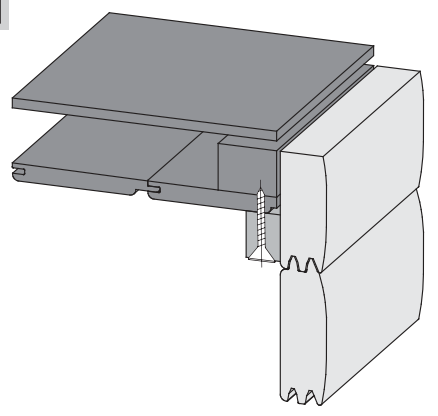

23

Ø5mm 6x100

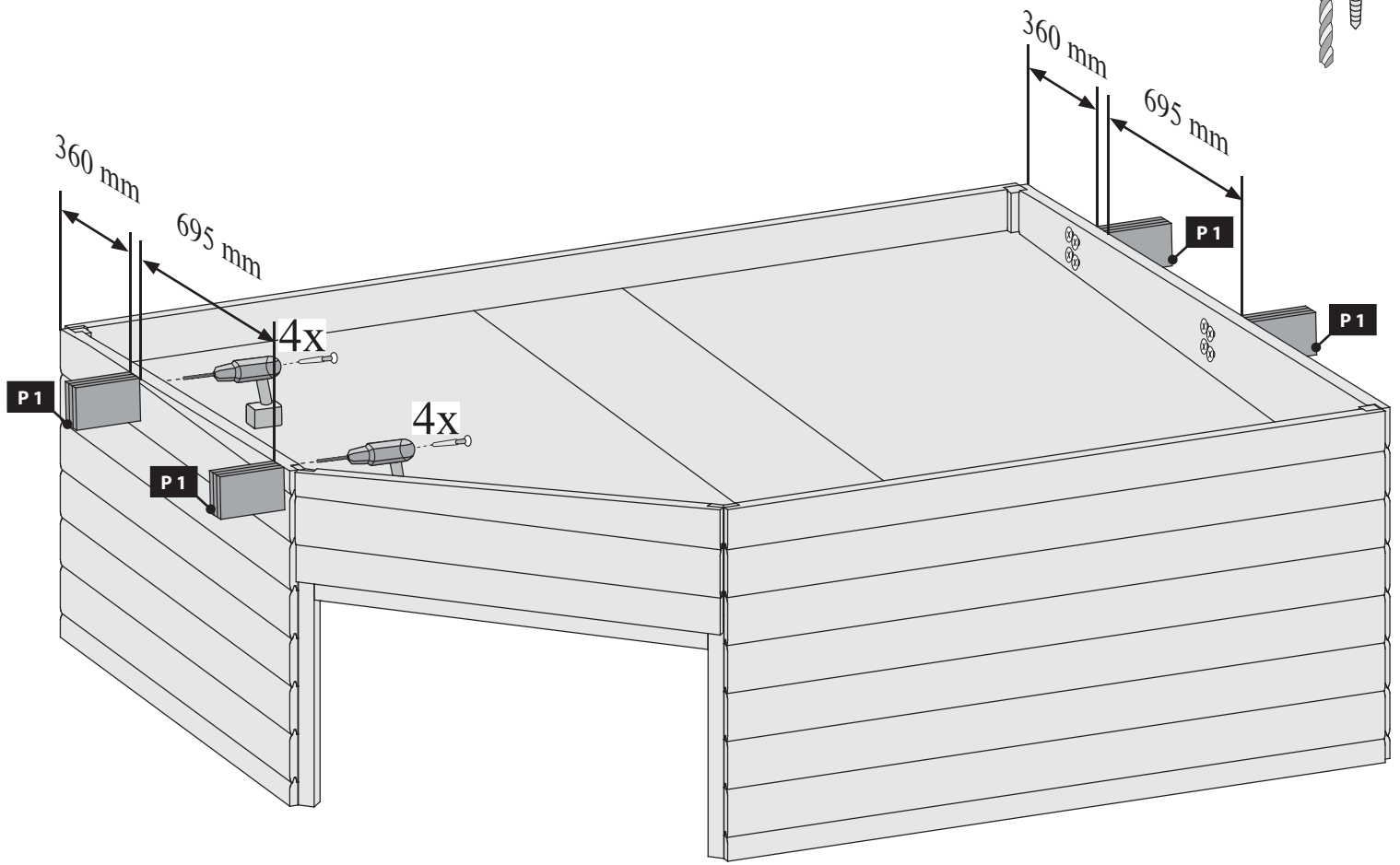

24

Ø3mm 4x35

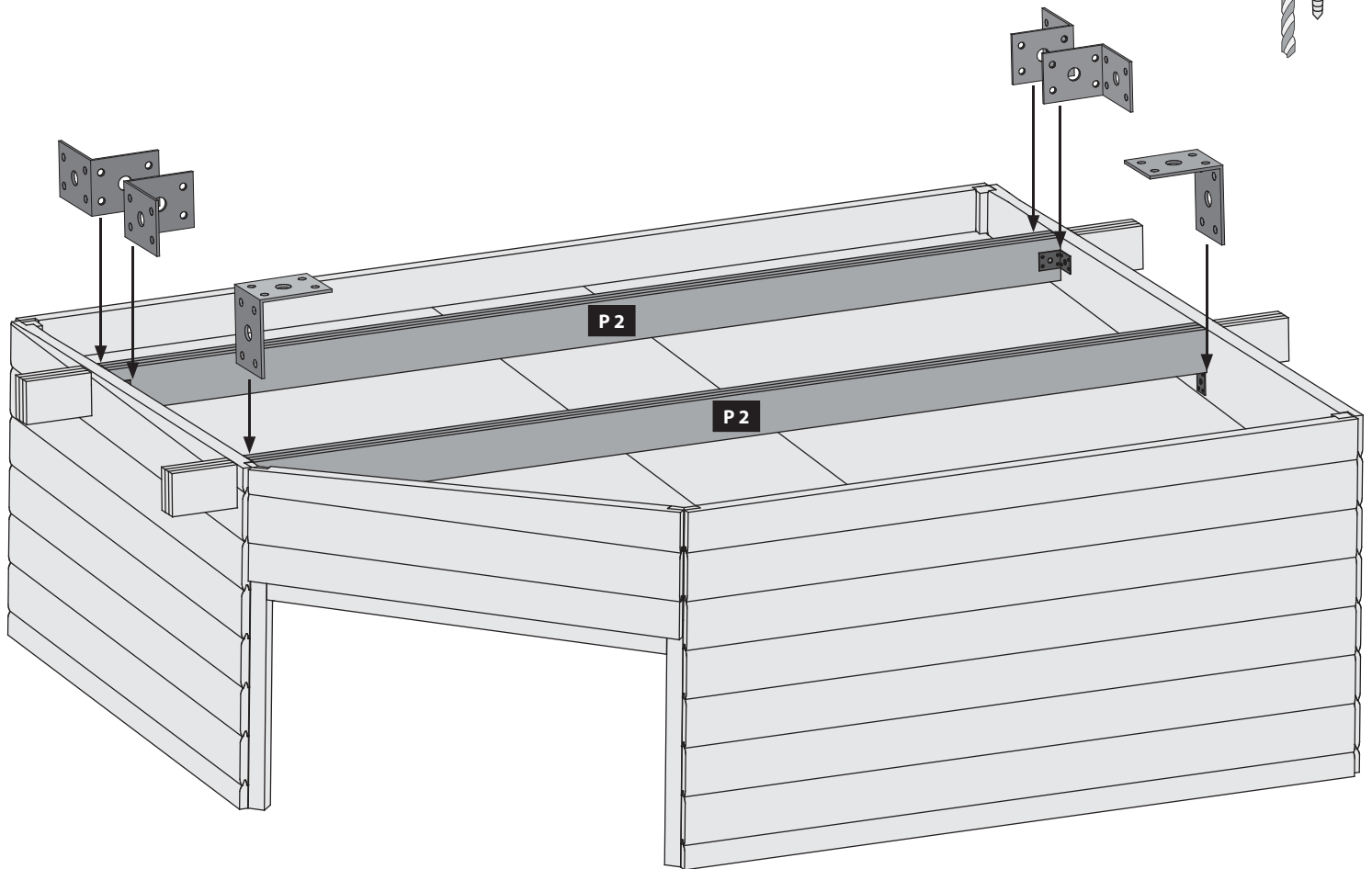

25

Bündig!
 Affleurement!
 Gelijk!
 Aras!
 Flush!
 Combacia!
 Flush!

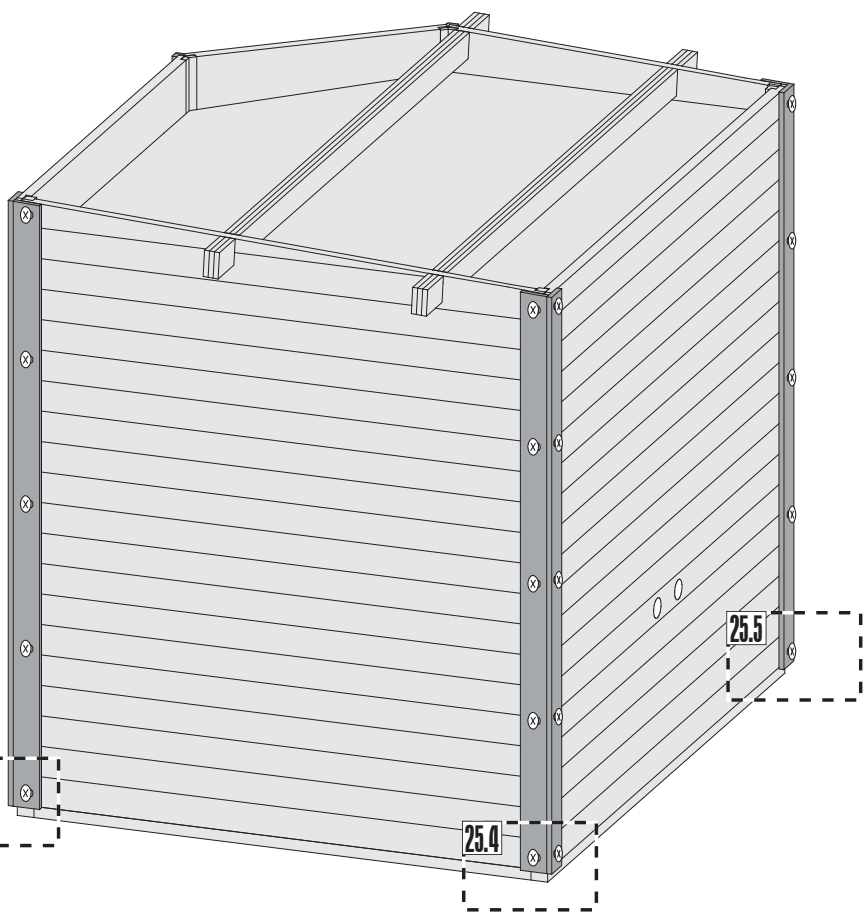
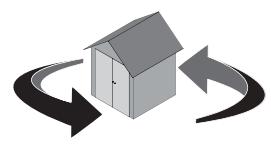
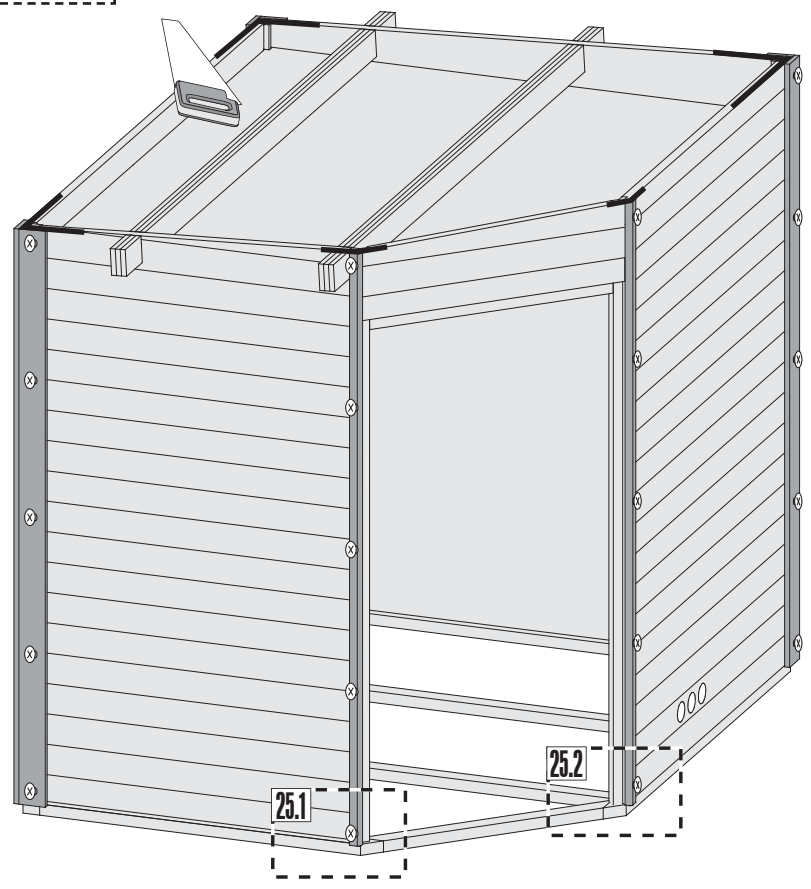
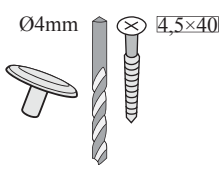
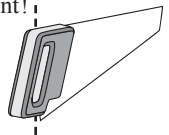

25.1

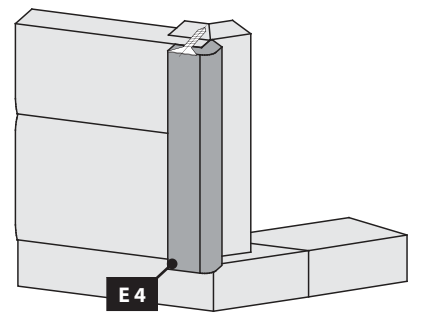

25.2

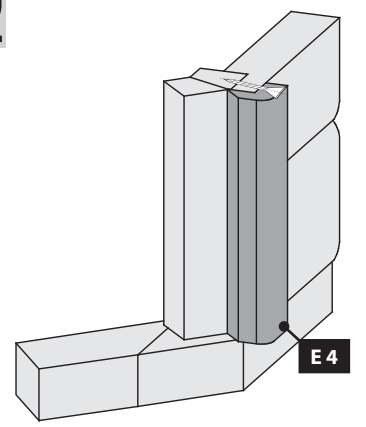

25.3

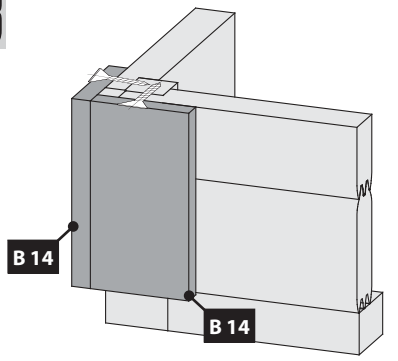

25.4

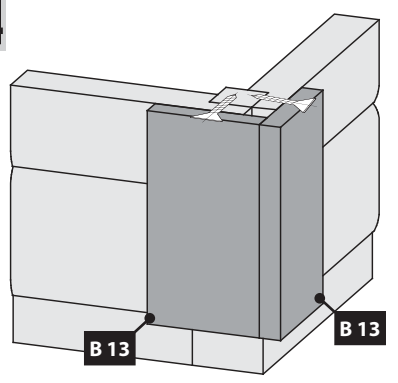

25.5

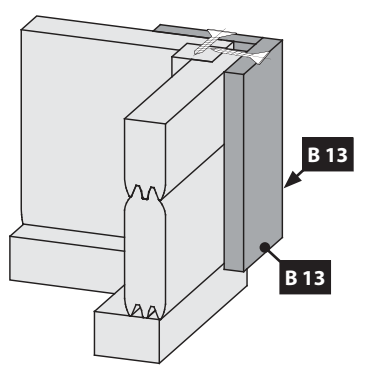

26

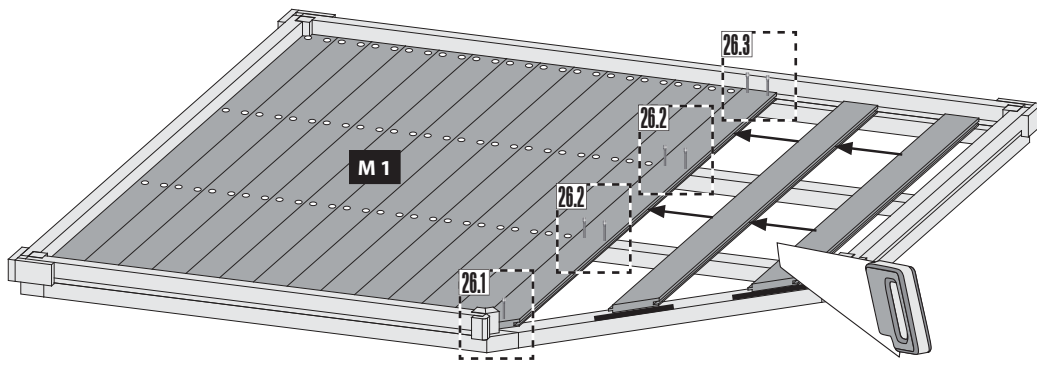

26.1

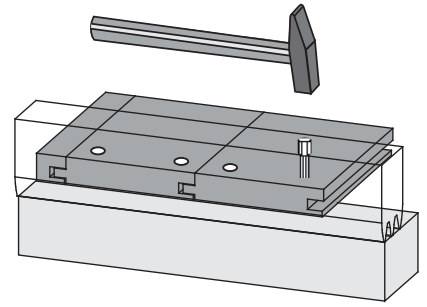

27

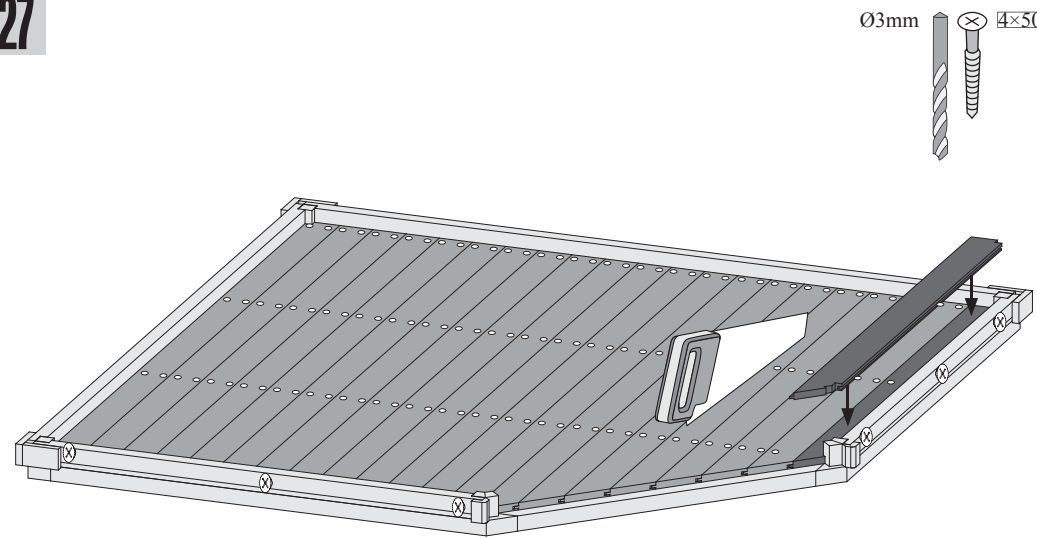

Ø3mm  4x50

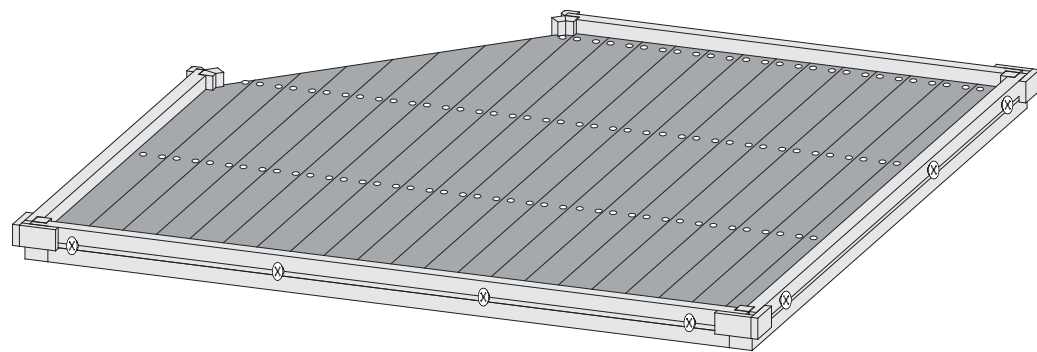
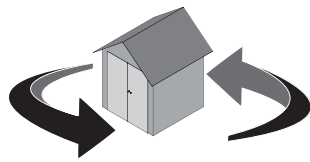

26.2

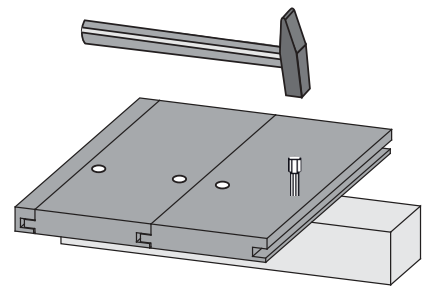

26.3

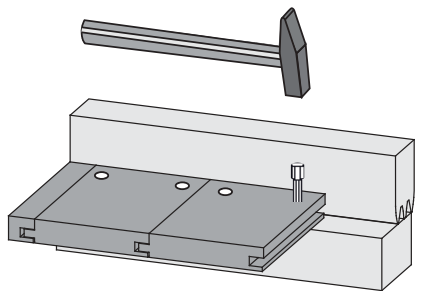

28

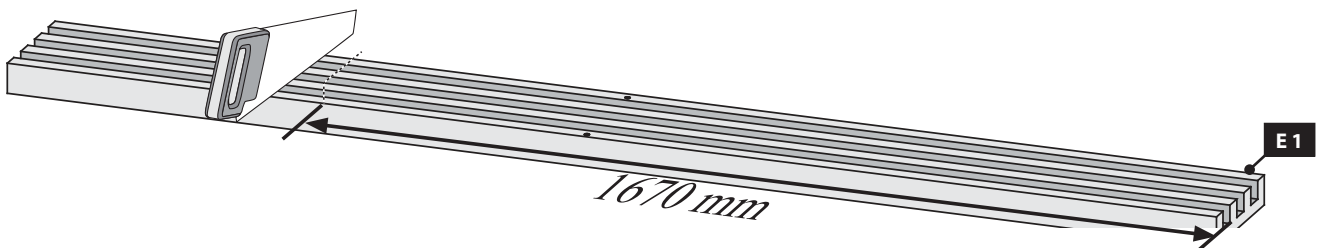

29 2x

Ø3mm 4x30

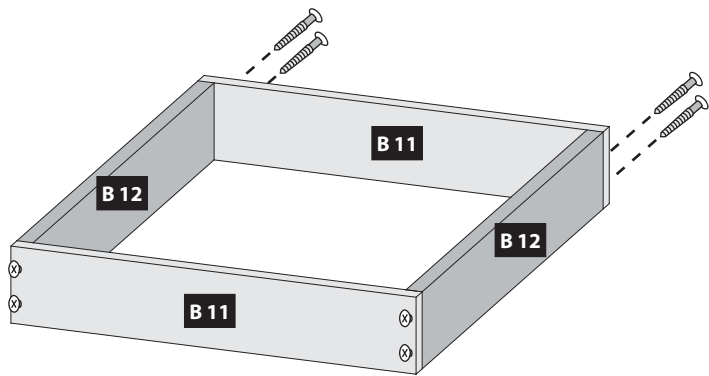

30 a

Ø3mm 4x30

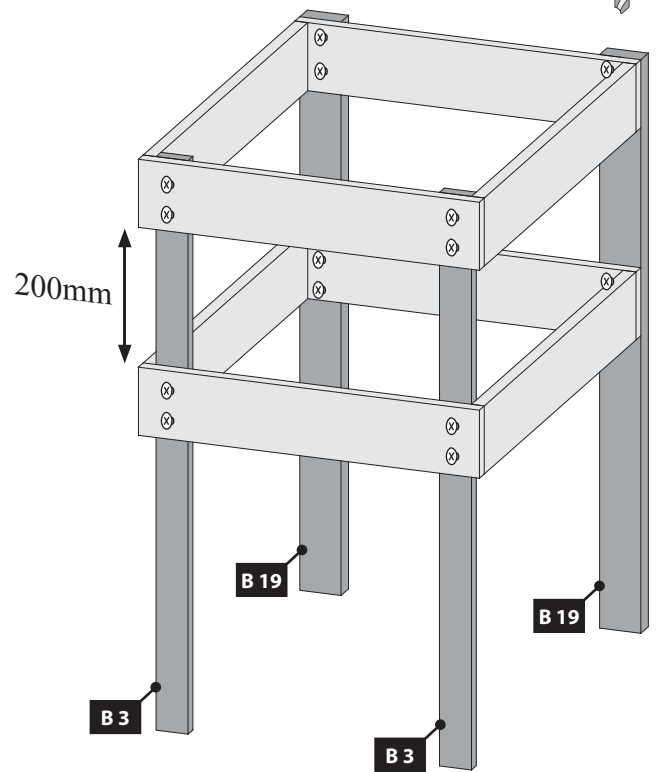

30 b

-  Nur bei 9 kW-Ofen
-  Seulement 9 kW chauffe
-  Only 9 kW heater
-  Slechts 9 kW heater
-  Sólo calentador de 9 kW
-  Solo riscaldamento 9 kW
-  Pouze topné těleso 9 kW

4x

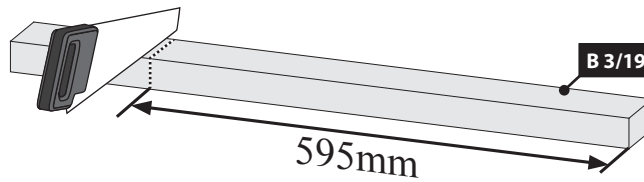

Ø3mm 4x30

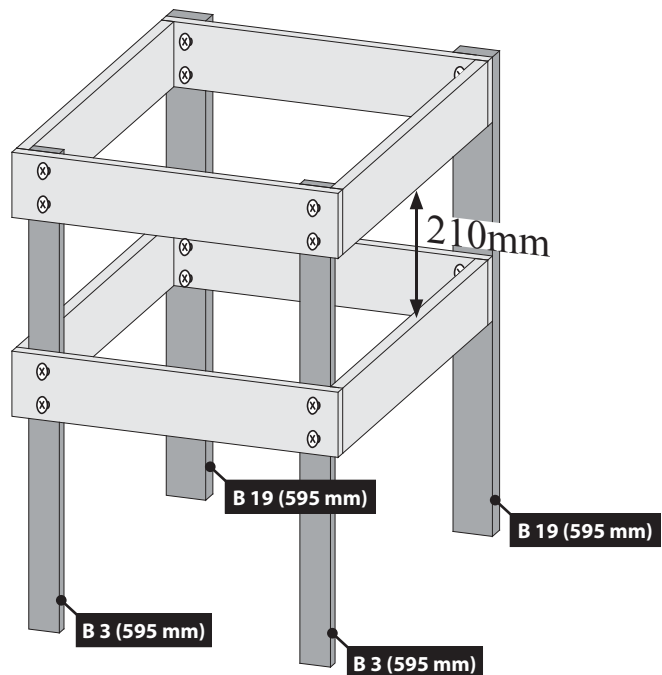

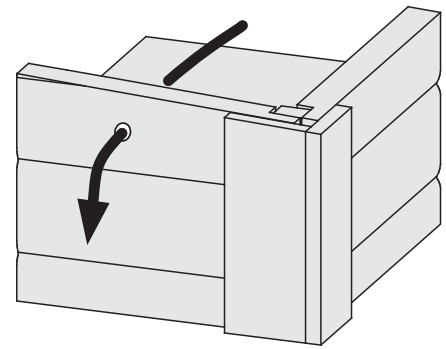
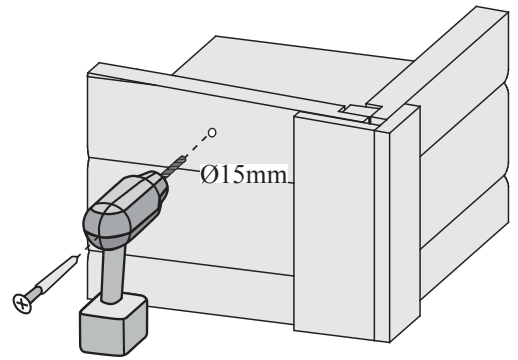
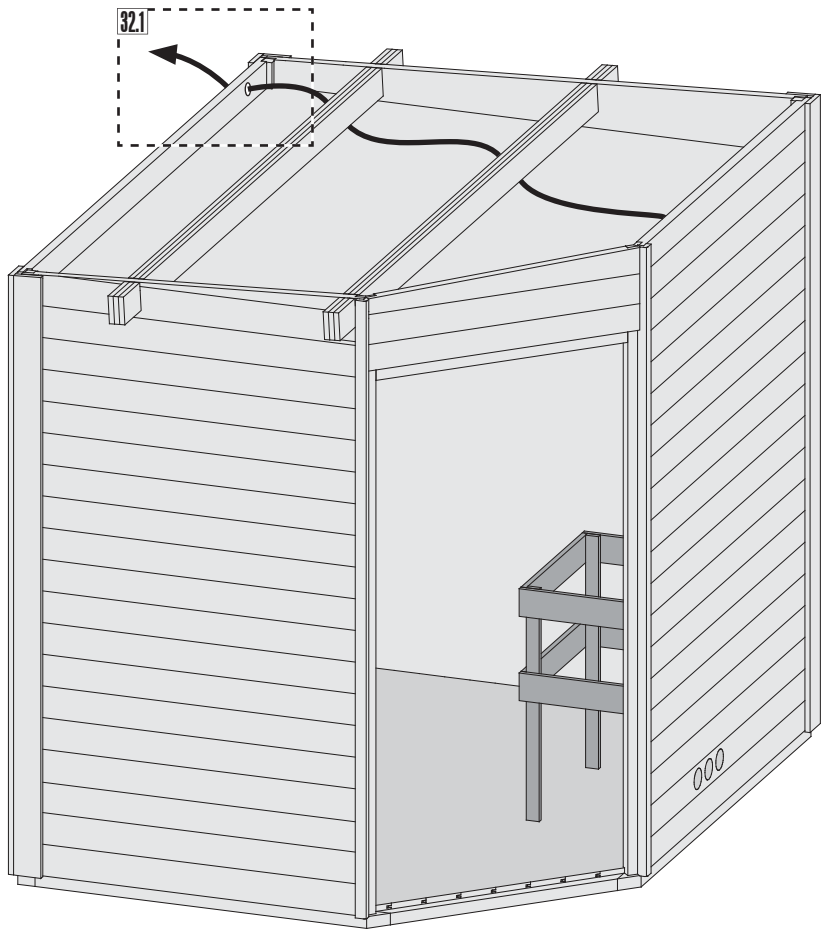
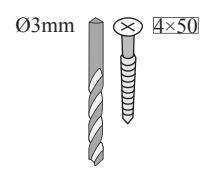
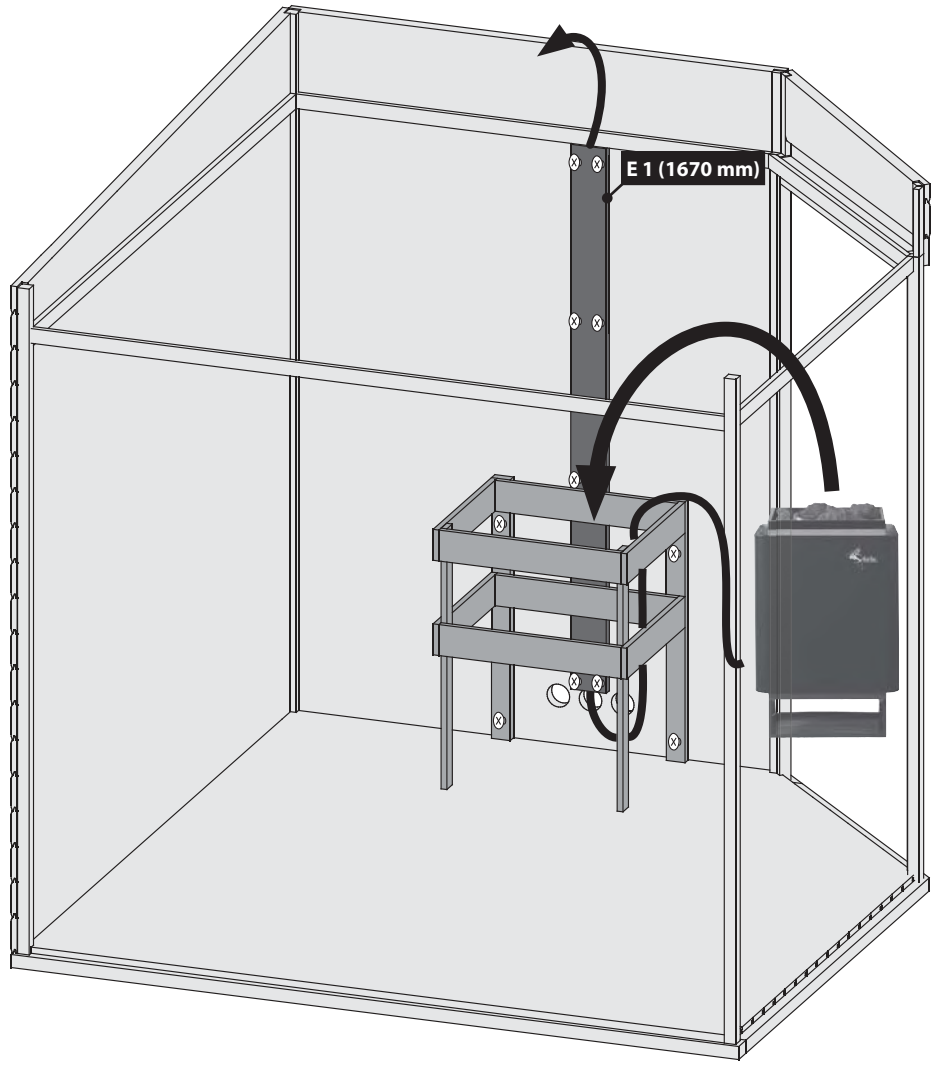

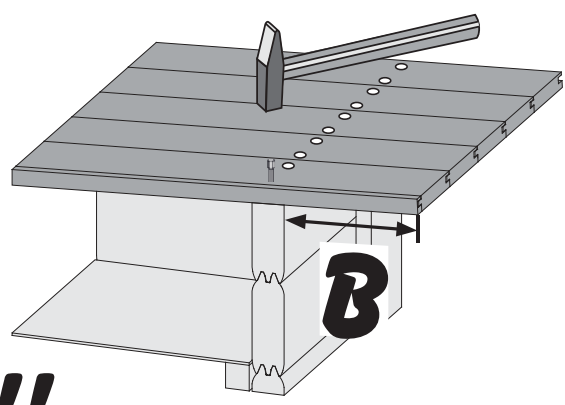
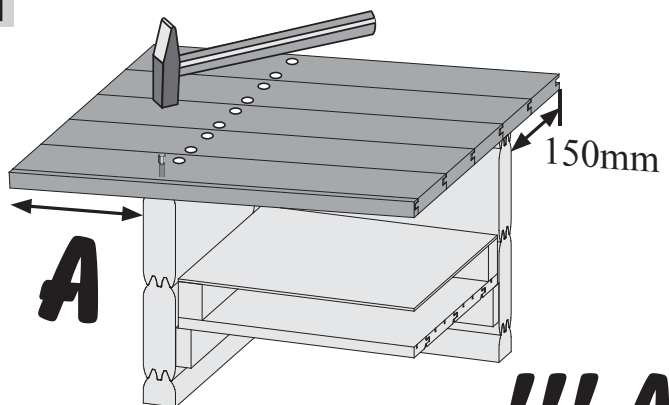
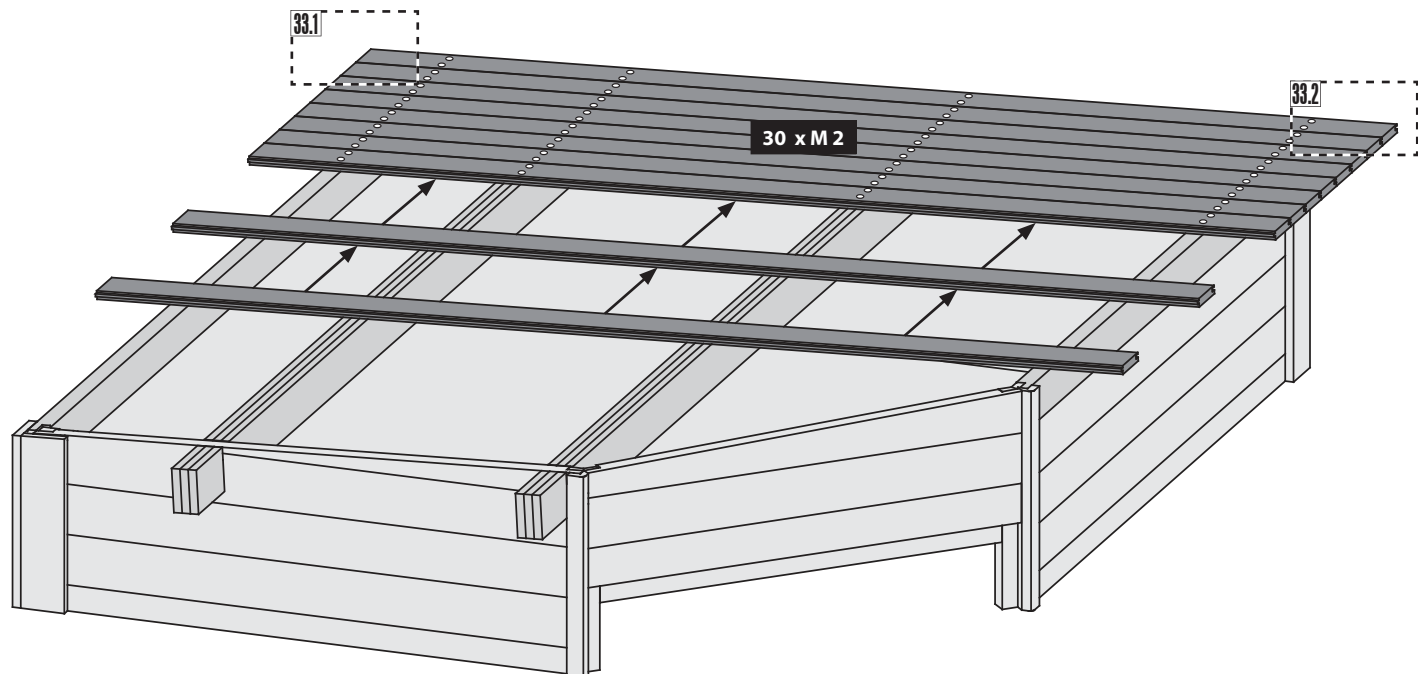

!!! A=B !!!

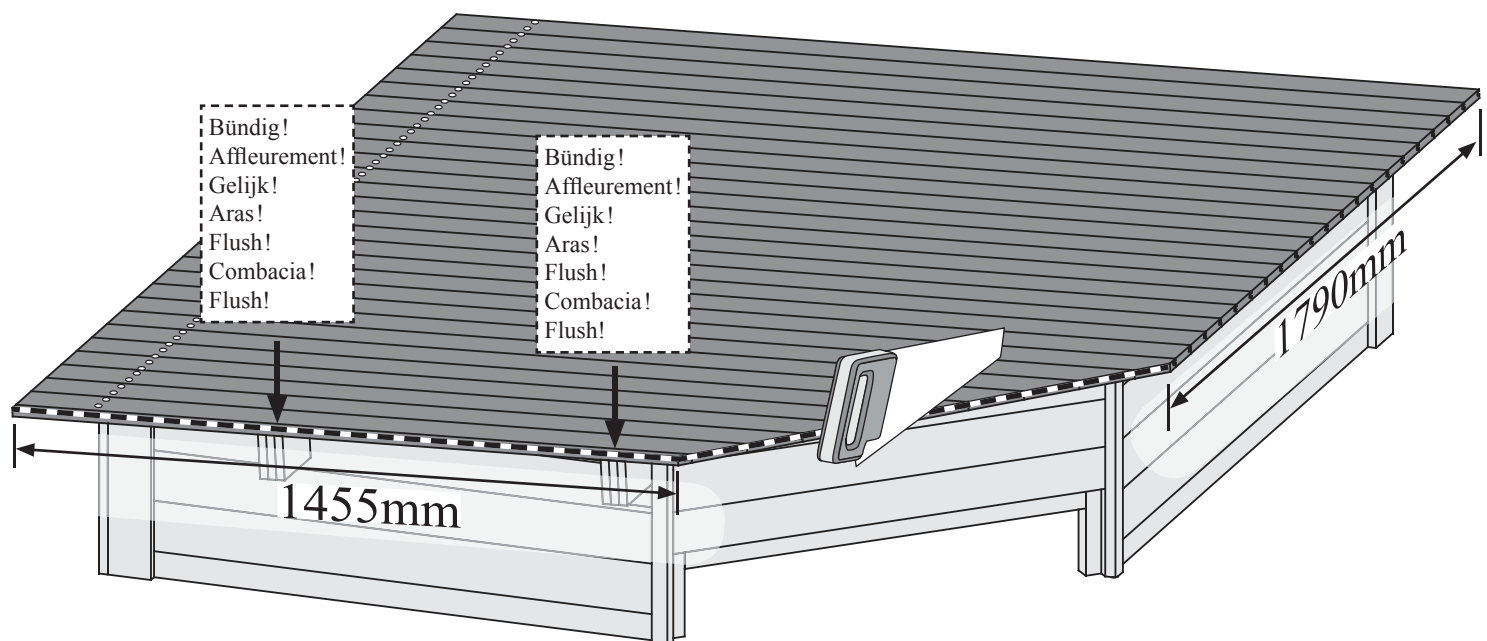

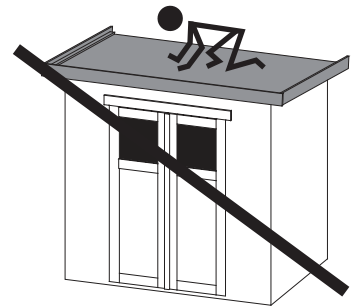
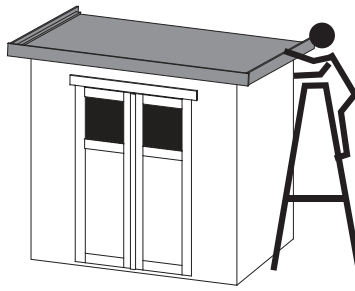
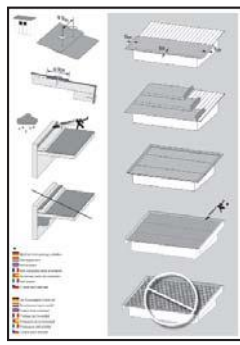
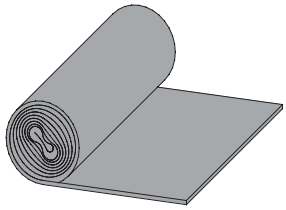

35

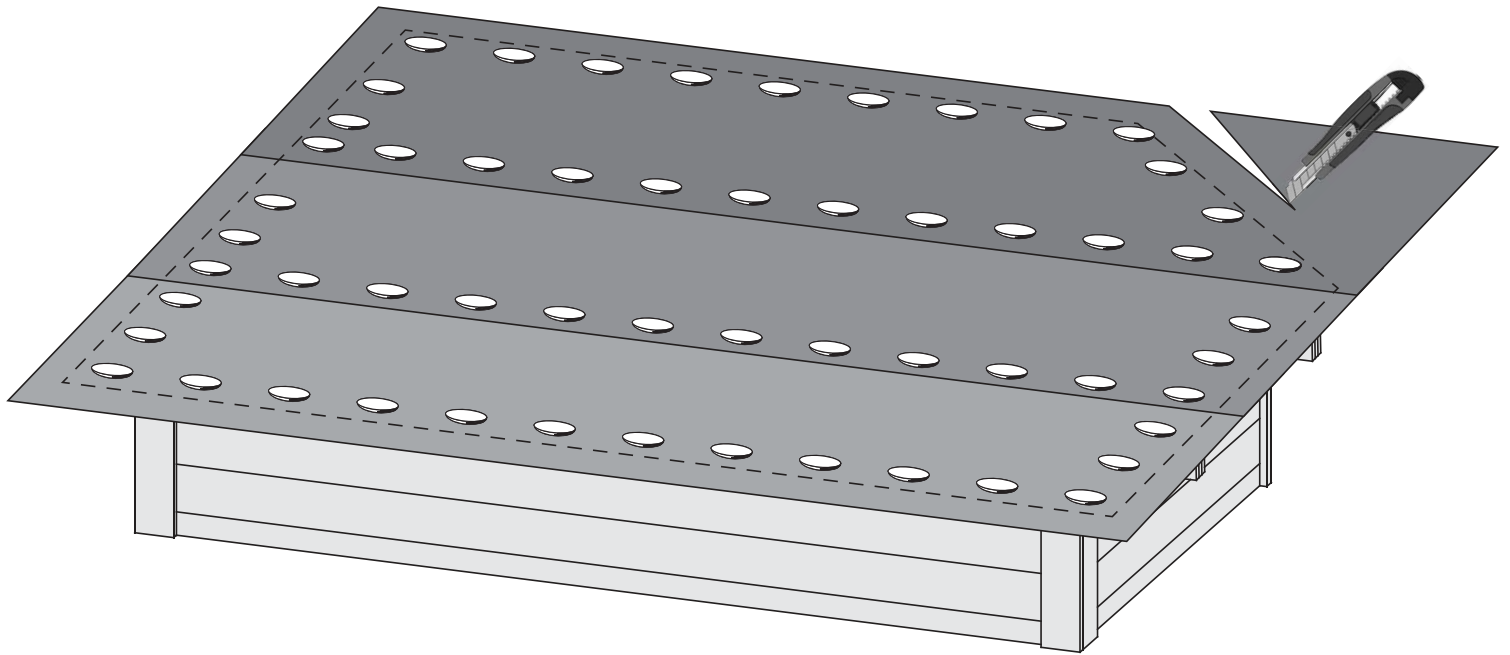

36 1x

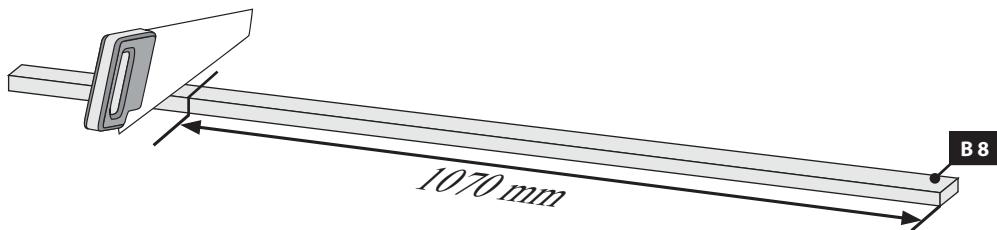

37 1x

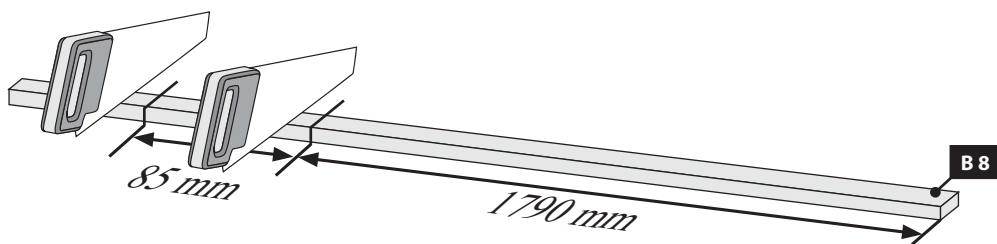

38 1x

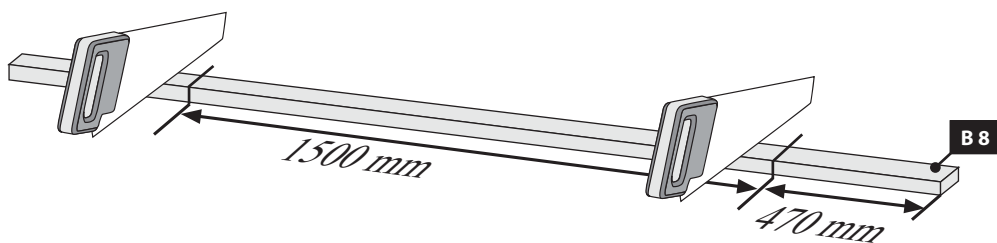

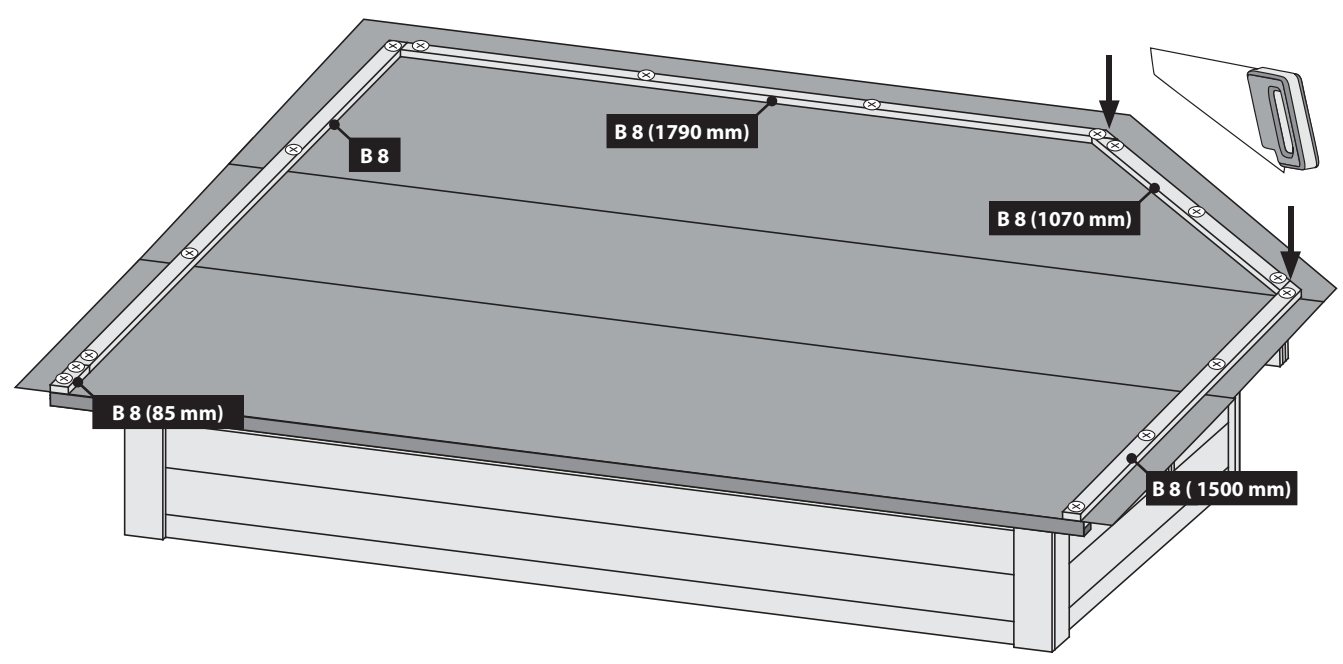
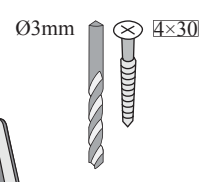
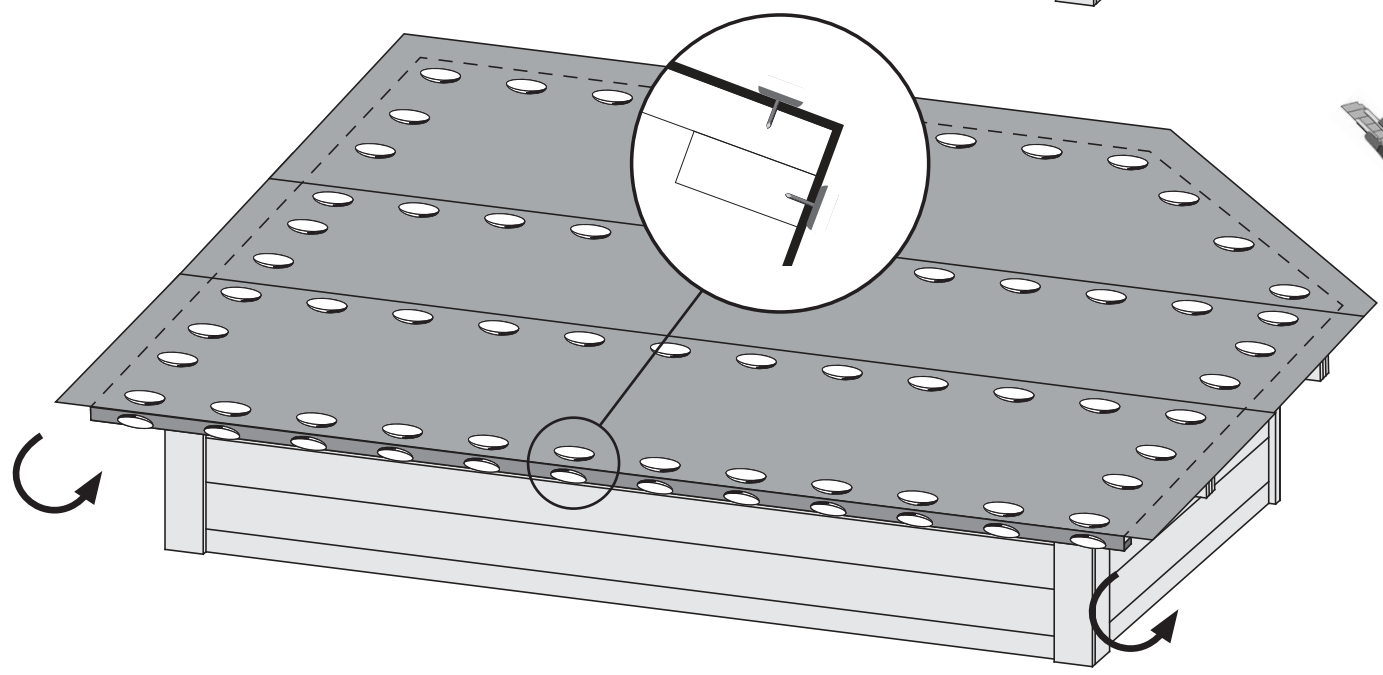
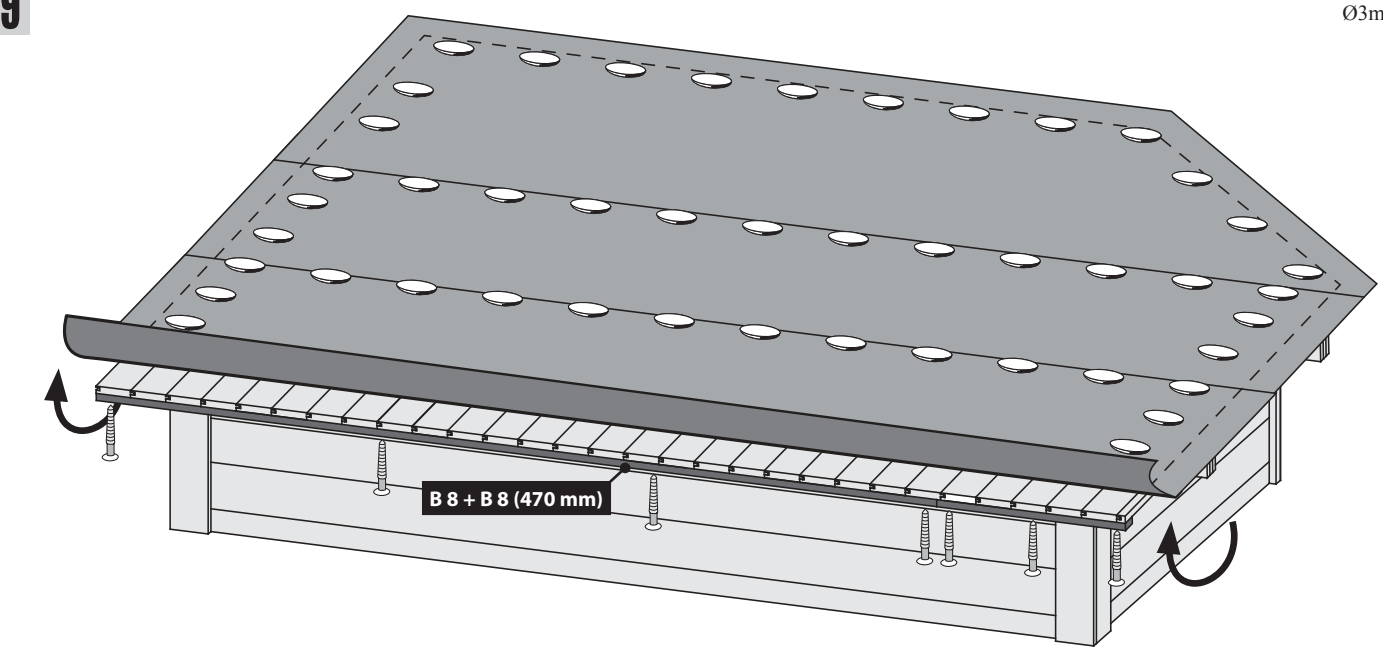
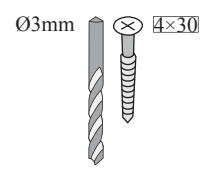





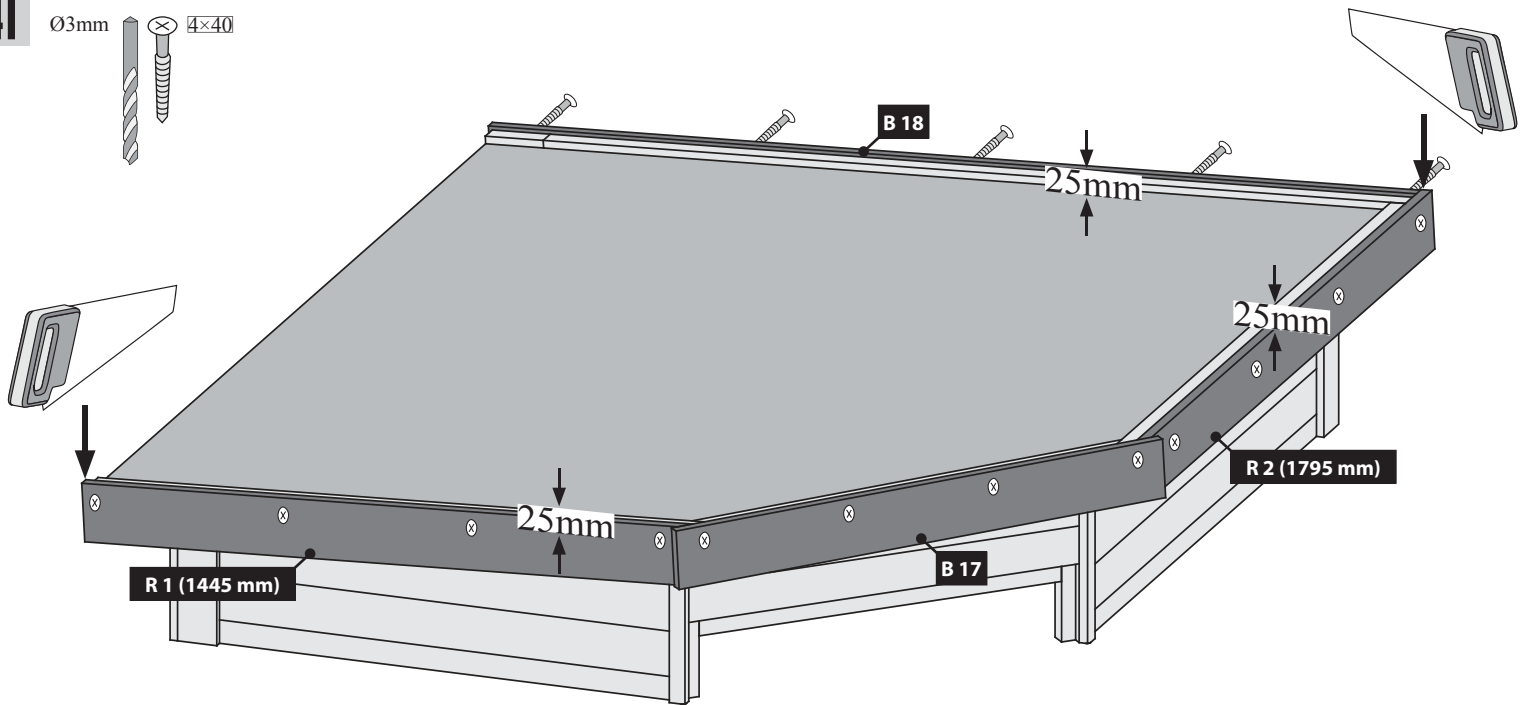

41

Ø3mm 4x40



-  Für die dauerhafte Eindeckung empfehlen wir die selbstklebende Bitumendachbahn aus unserem Sortiment
-  For permanent covering, we recommend self-adhesive bitumen roofing sheet from our range
-  Pour revêtement permanent, nous vous recommandons de bitume auto-adhésif tôle de toiture de notre gamme
-  Voor permanente bedekking, raden wij zelfklevende bitumen dakbaan uit ons assortiment
-  Para cobertura permanente, recomendamos betún autoadhesivas Perfil de cubierta de nuestra gama
-  Per copertura permanente, si consiglia di bitume autoadesive Lastra per coperture della nostra gamma
-  Pro trvalé krytinou, doporučujeme samolepicí asfaltové střešní krytiny z našeho sortimentu

42

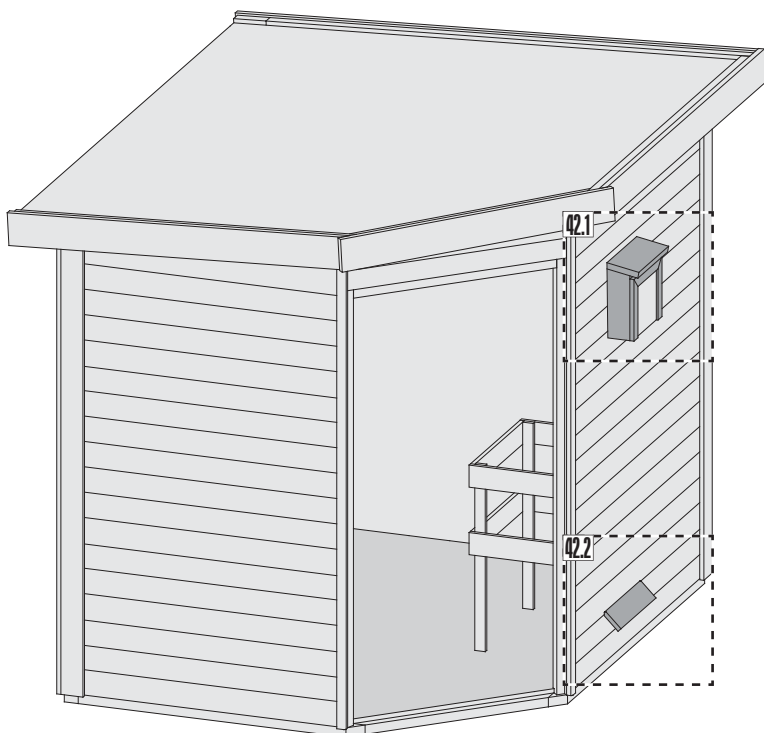

42.1

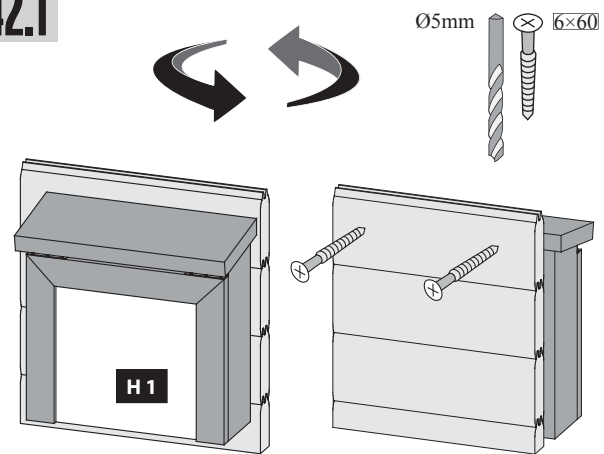

42.2

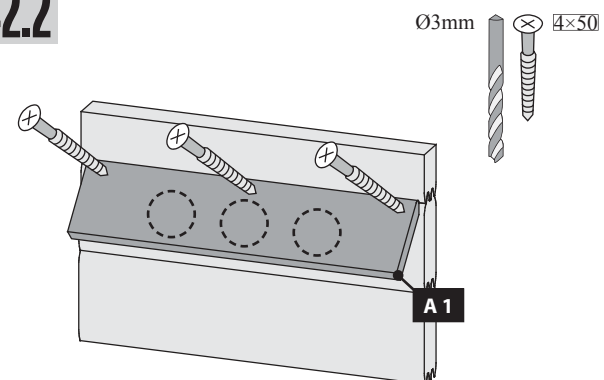

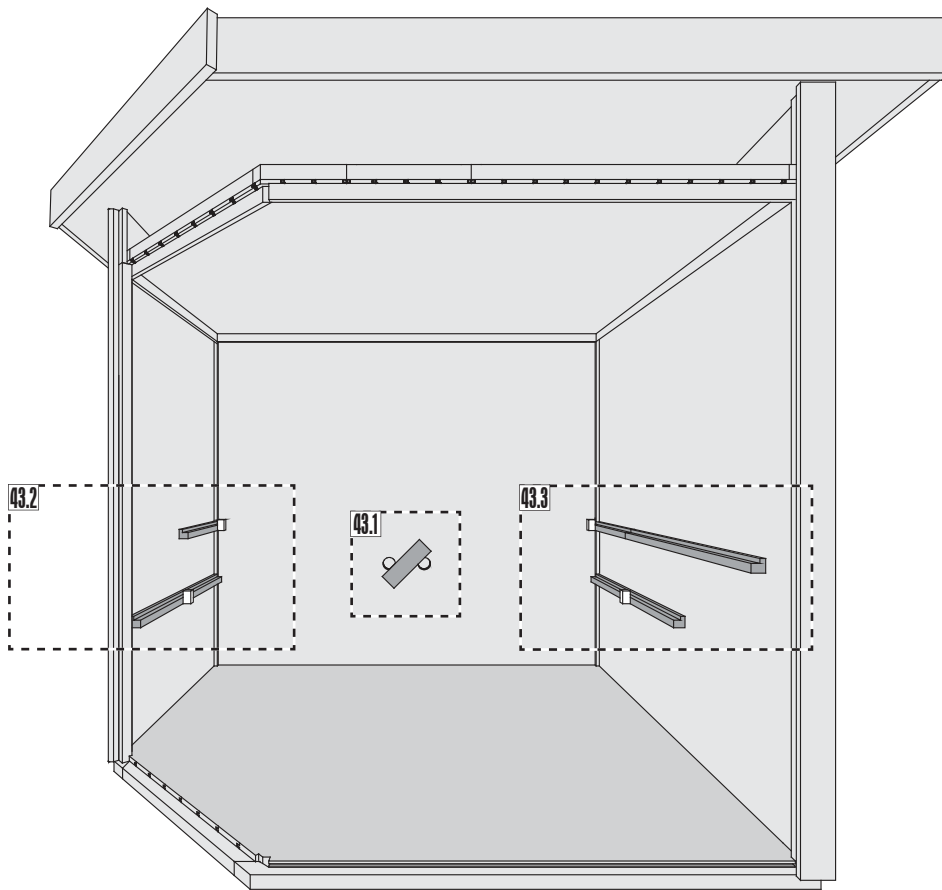

43.1-1

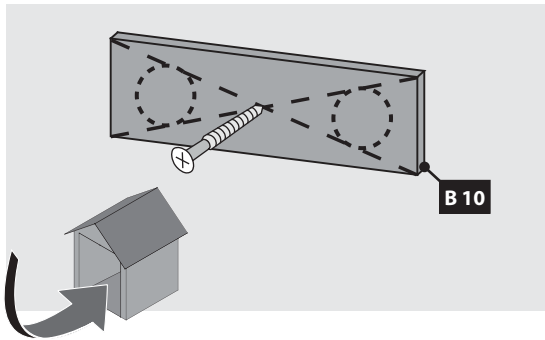
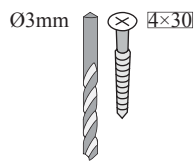

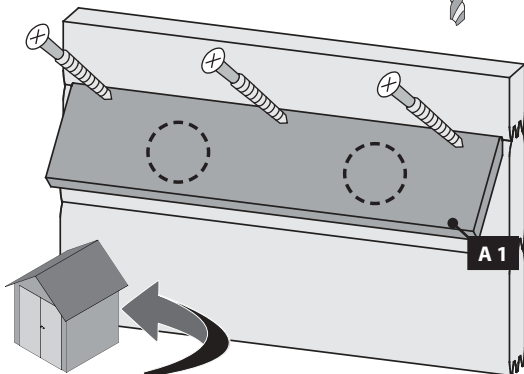
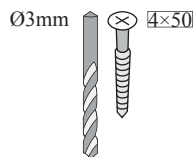

B 10



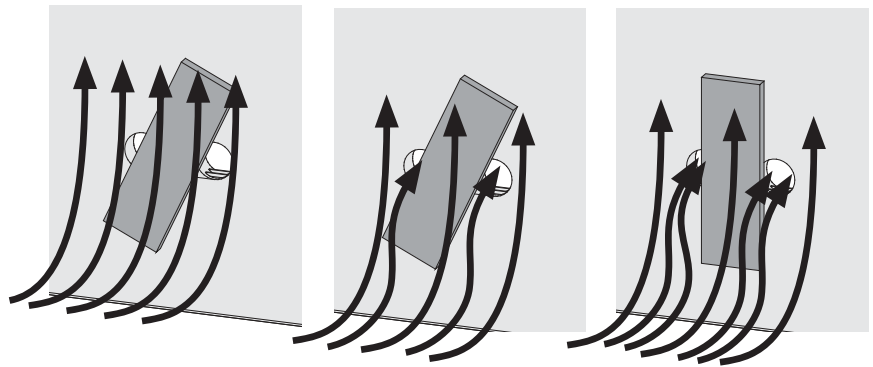

A 1

43.1-2





 Hier ist die Funktionsweise des Brettes abgebildet. Regeln Sie damit die Abluft nach Ihren eigenen Wünschen.

 Hier is de werking van het plankje afgebeeld. Regel daarmee de lucht afvoer naar eigen wens.

 Zde je zobrazená funkce desky. Regulujte s ní odsávací vzduch dle Vašeho přání.

 Ceci représente le mode de fonctionnement de la planche. Avec elle, réglez l'écoulement de l'air selon vos désirs.

 Aquí está representada la forma de funcionamiento de la tabla. Regule con ello el aire de salida según sus propios deseos.

 This figure shows the functional principle of the board. Regulate the exhaust air according to your own wishes.

 Viene illustrato il principio di funzionamento della tavoletta di regolazione della ventilazione. Con essa si può regolare a piacere la ventilazione.

43.2-1

Ø5mm 6×80

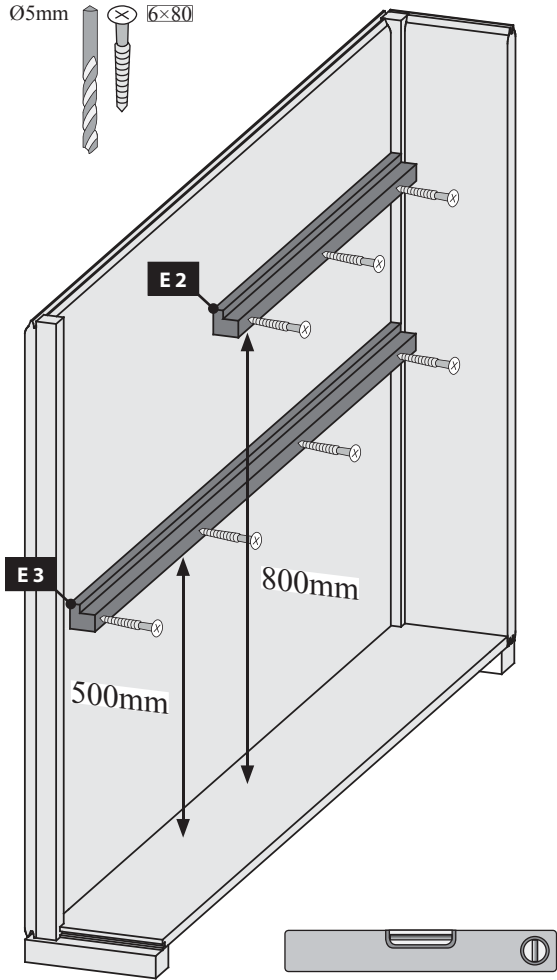
**43.2-2**

Ø5mm 6×90

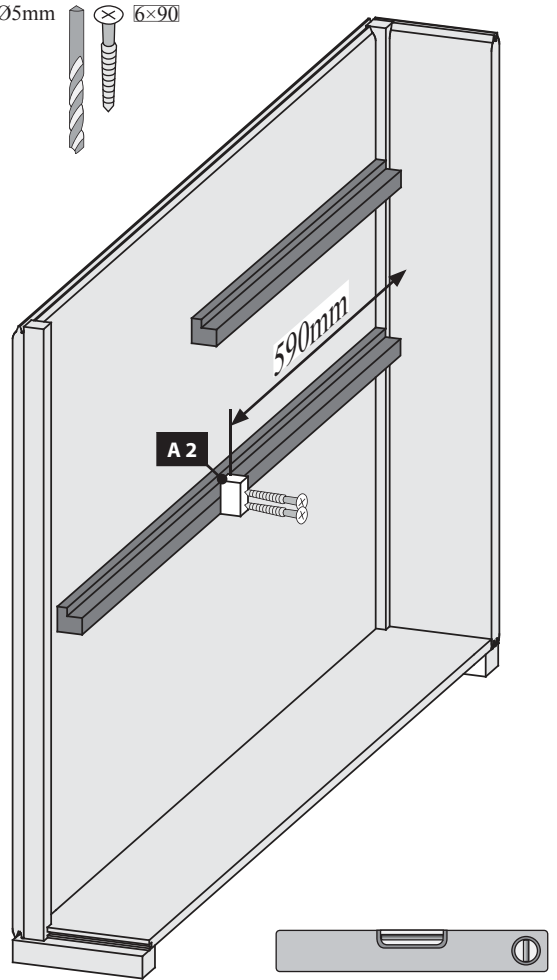
**43.3-1**

Ø5mm 6×80

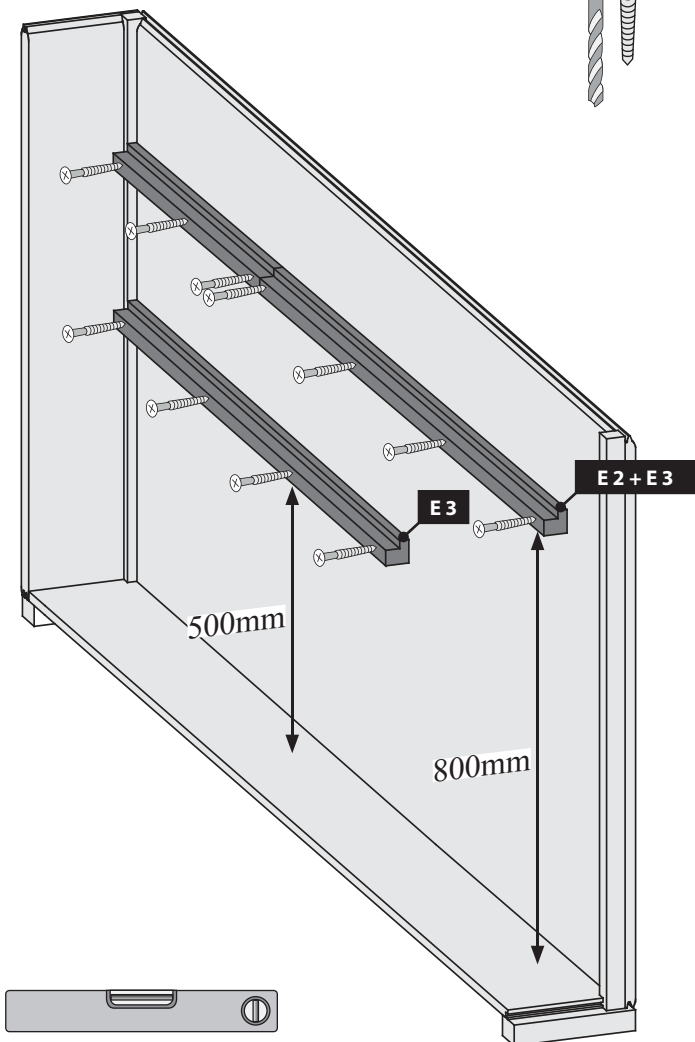
**43.3-2**

Ø5mm 6×90

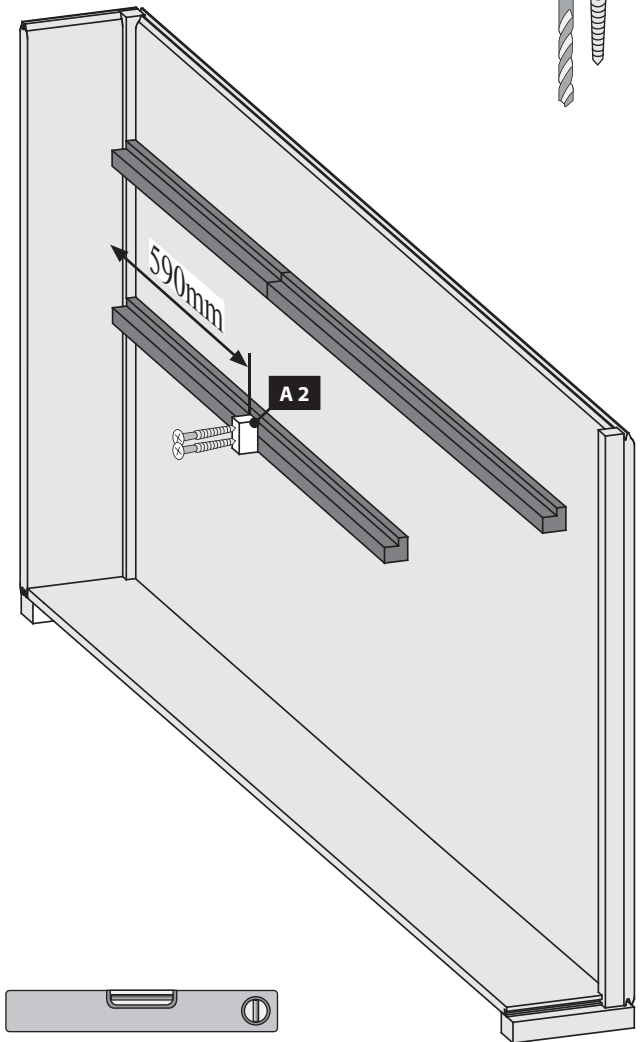

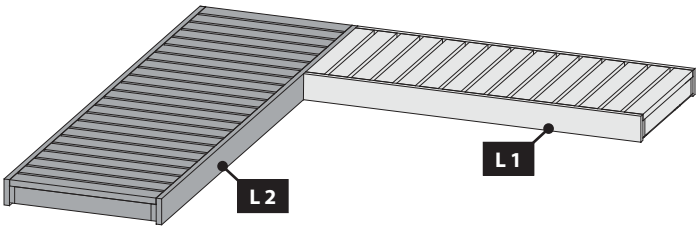
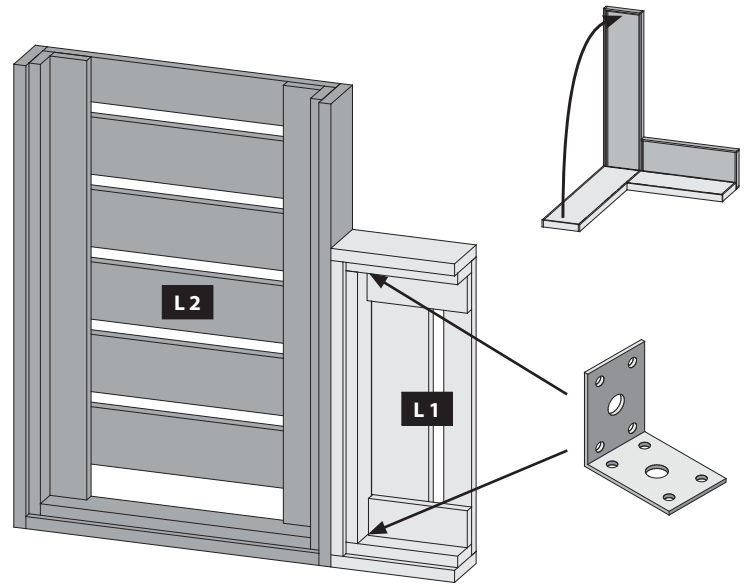
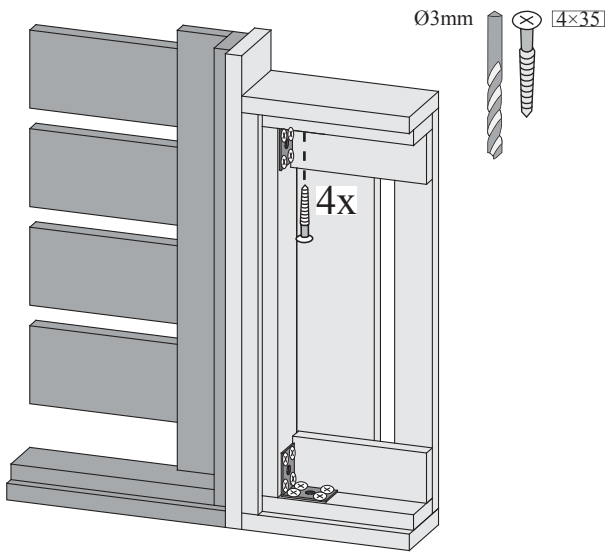
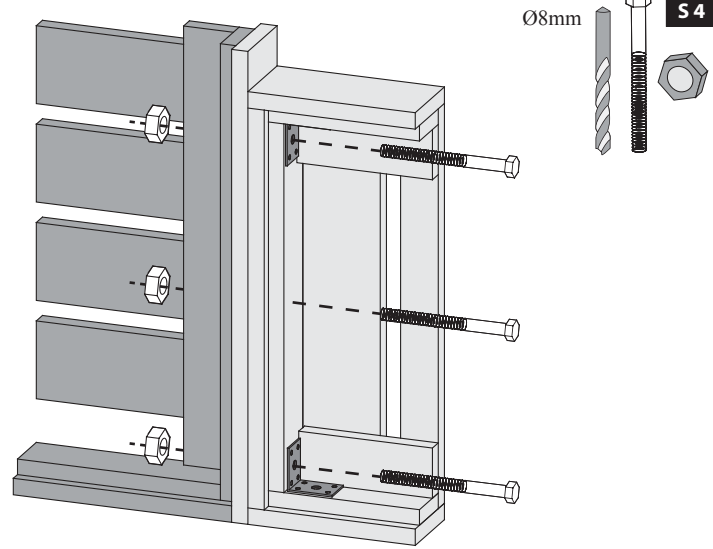
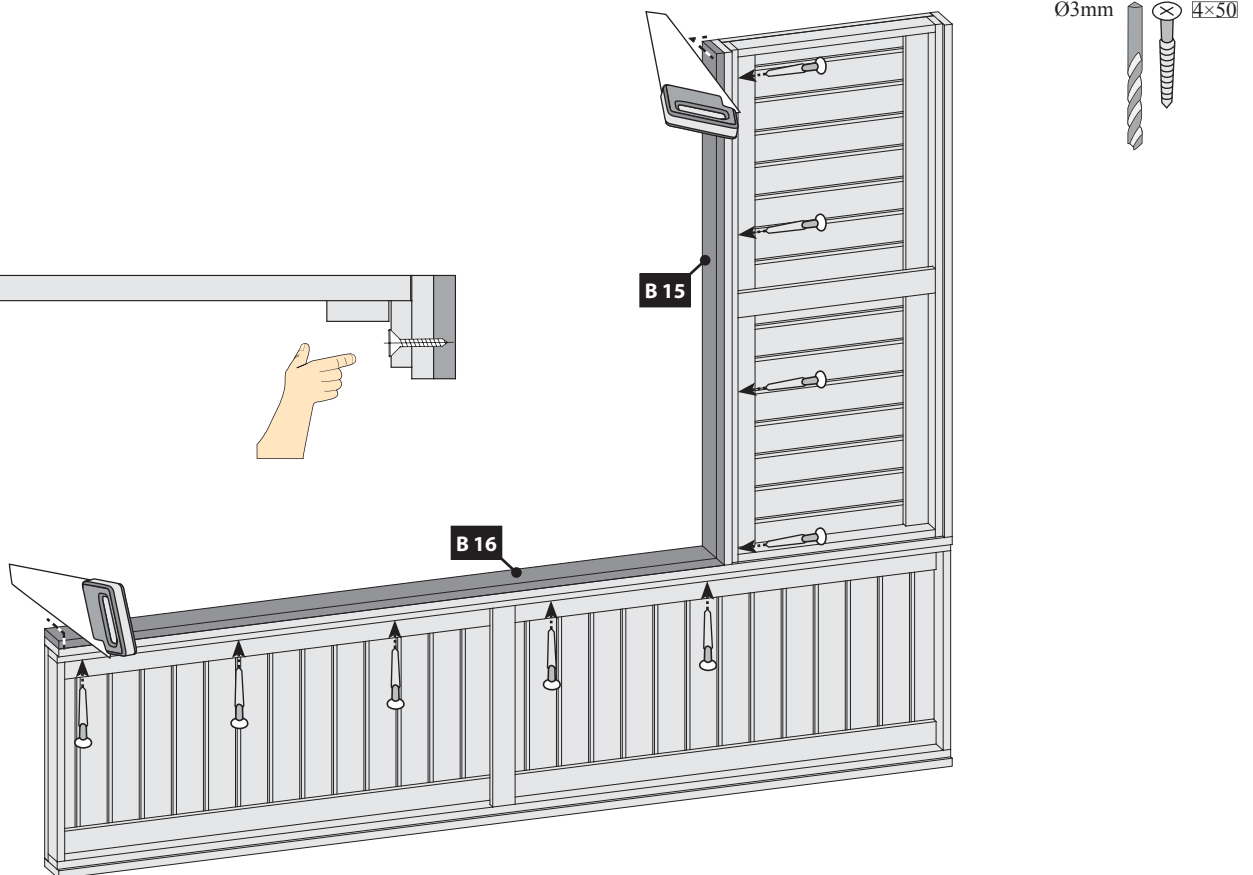
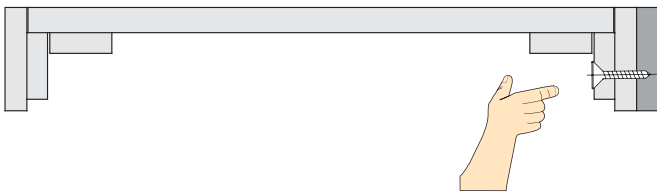
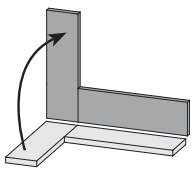
44**45****46****47****48**

49 1x

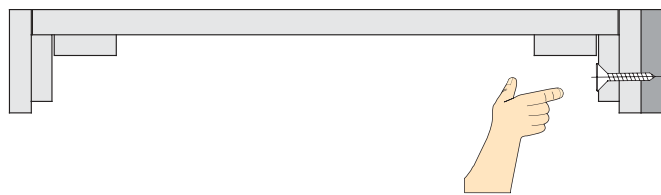

Ø3mm 4x50

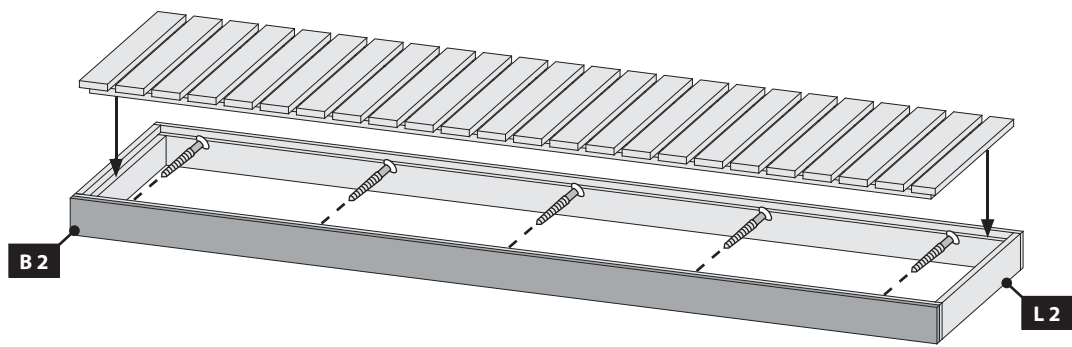



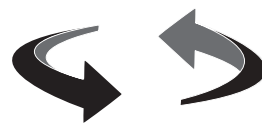

50

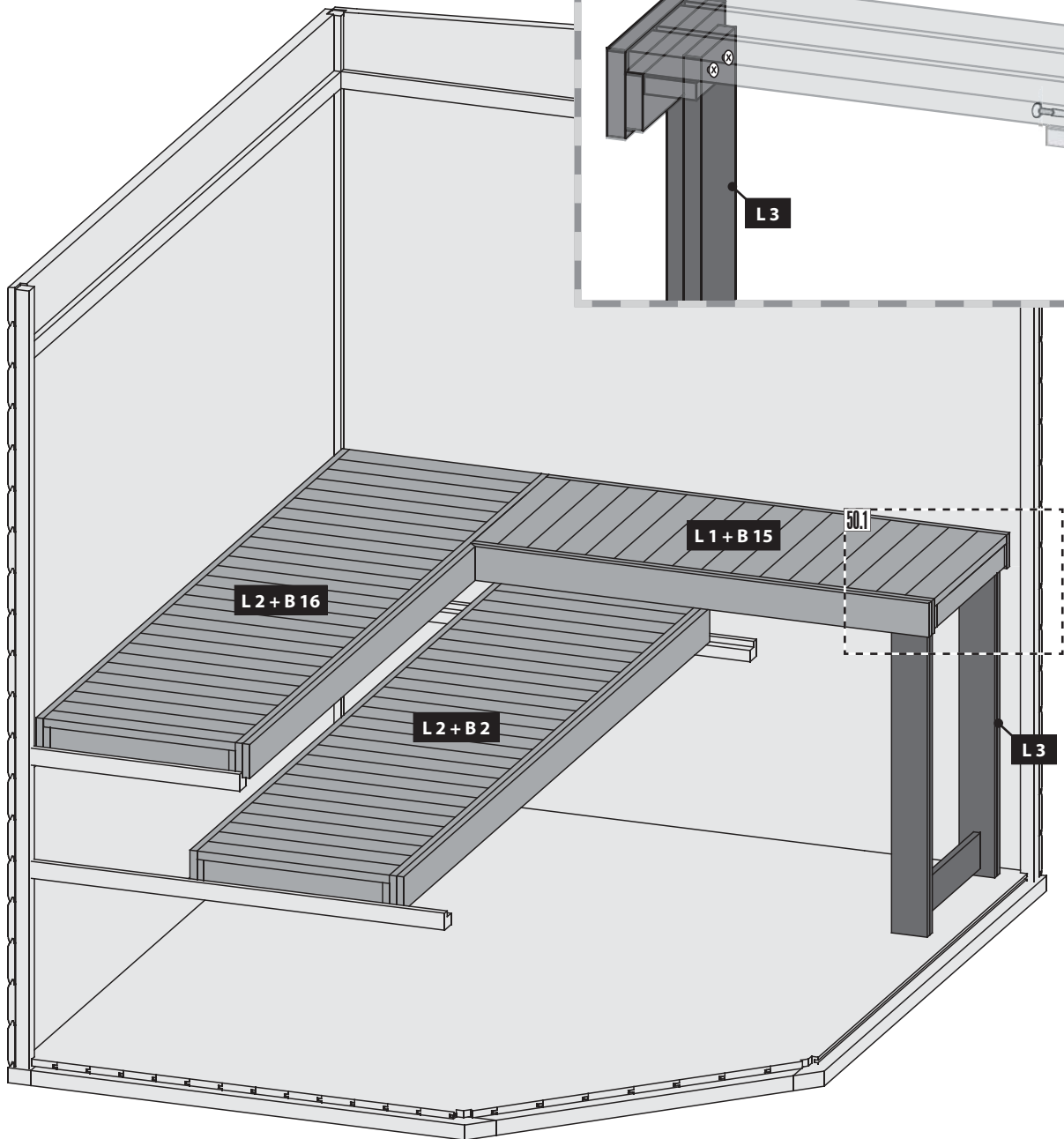
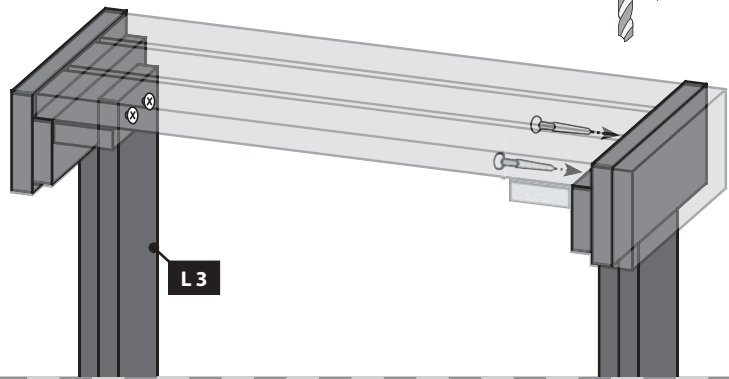

50.1





Ø3mm 4x35







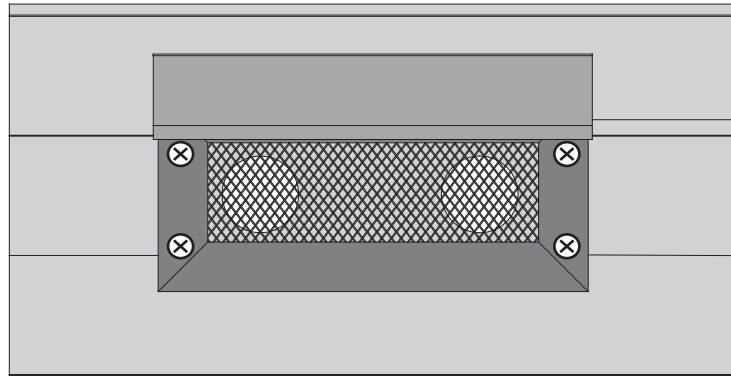
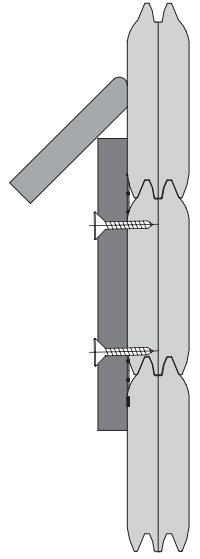
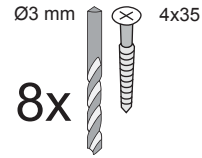
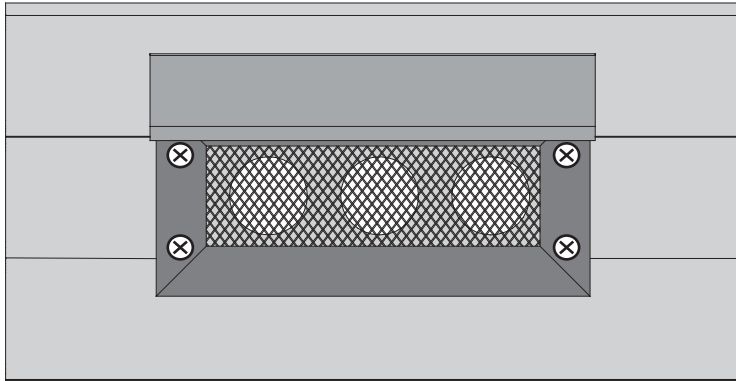

-  Saunahaus ohne Vorraum
-  Saunahuis zonder voorkamer
-  Sauna sans antichambre



-  Sauna Sin antesala
-  Sauna house without anteroom
-  Sauna senza antibagno

-  Saunový dům bez předsíně
-  Sauna hus uden anteroom



-  Saunahaus mit Vorraum
-  Saunahuis met voorkamer
-  Sauna avec antichambre

-  Sauna con antesala
-  Sauna house with anteroom
-  Sauna con antibagno

-  Saunový dům s předsíní
-  Sauna hus med anteroom

